Automatic drink vending machine

Model

PHEDRA



Type: D.A. 5P07



WARNING: This instruction manual is intended exclusively for specialized personnel.

For more information visit www.Gumball.com | 800-260-0010 | +1-214-550-5079

USE AND MAINTENANCE

CONTENTS

CONTENTS	2	7.5	Coffee grinding calibration	25	
MAIN PARTS - ESPRESSO VERSION.....	3	7.6	Dose calibration	25	
MAIN PARTS - INSTANT VERSION.....	5	7.7	First start-up of the vending machine.....	26	
MAIN PARTS - T.T.T. VERSION	7	7.8	Filling the boiler manually	26	
MAIN PARTS - CAPPUCCINO VERSION	9	7.9	Use of the vending machine	26	
1 - INTRODUCTION TO THE MANUAL... 11		8 - PROGRAMMING AND MAINTENANCE MENU	27		
1.1	Introduction.....	11	8.1	Key description of programming and maintenance phases	27
1.2	Symbols used.....	11	8.2	Programming menu	27
2 - INFORMATION ON THE VENDING MACHINE... 11		8.2.1	Entering the programming menu	27	
2.1	Information for the Maintenance Technician.....	11	8.2.2	Structure of the programming menu	28
2.2	Description and intended use.....	12	8.2.3	Description of messages in the programming menu	29
2.3	Vending Machine Identification	12	8.3	Maintenance menu	41
2.4.	Technical specifications	13	8.3.1	Entering the maintenance menu.....	41
3 SAFETY	13	8.3.2	Structure of the maintenance menu.....	41	
3.1	Introduction.....	13	8.3.3	Description of messages in the maintenance menu	41
3.2	General safety regulations.....	13	8.4	Machine Ready/Free Button	43
3.3	Operators' requirements	14	8.5	Reset	43
3.4	Safety devices	14	9 - OPERATION AND USE	44	
3.5	Residual risks	15	9.1	Beverage selection	44
4 - HANDLING AND STORAGE.....	15	9.2	Cappuccino with cold milk function (only for Cappuccino version).....	44	
4.1	Unloading and handling	15	10 - CLEANING AND MAINTENANCE	44	
4.2	Storage	15	10.1	General notes for correct operation.....	45
5 - INSTALLATION	15	10.2	Cleaning and scheduled maintenance	45	
5.1	Important	15	10.2.1	Maintenance schedule	45
5.2	Unpacking and positioning	16	10.2.2	Cleaning the Drip Tray and the Coffee Grounds Drawer.....	45
5.3	Label application	16	10.2.3	Cleaning the tray and drawer - Version with extension	45
5.4	Fitting the payment systems	17	10.2.4	Cleaning of the coffee brew group	46
5.5	Connection to water mains	18	10.2.5	Cleaning the dispensing arm	46
5.6	Connection to the electric network.....	18	10.2.6	Cleaning the instant product dispenser and the mixer	47
5.7	Coffee Grounds Discharge Setting	19	10.2.7	Cleaning the containers	48
5.8	Liquid Drain Setting	19	10.2.8	Cleaning the coffee grinder.....	48
5.9	Drip Tray Locking	20	10.2.9	Semi-automatic cleaning of the Cappuccinatore (only for Cappuccino version)	49
5.10	Front Door Intermediate Locking	20	10.2.10	Manual cleaning of the Cappuccinatore (only for Cappuccino version)	50
6 - CONTROLS DESCRIPTION	21	10.3	Software Update	51	
6.1	Display	21	11 - DISPLAY MESSAGES	52	
6.2	Keypad.....	21	11.1	Messages during operation	52
6.3	Key description in standard operation mode.....	21	11.2	Error messages.....	52
6.4	CPU card keys.....	21	12 - STORAGE - DISPOSAL	54	
7 - SUPPLY AND STARTING UP	22	12.1	Change of location	54	
7.1	Container supply (Espresso).....	22	12.2	Inactivity and storage periods.....	54
7.2	Container supply (Instant).....	22	13 - INSTRUCTIONS FOR END-OF-LIFE DISPOSAL TREATMENT	54	
7.3	Container supply (T.T.T.)	23			
7.4	Container supply (Cappuccino)	23			
7.4.1	Coffee bean supply	24			
7.4.2	Instant product supply.....	24			

MAIN PARTS - ESPRESSO VERSION



Fig. 1

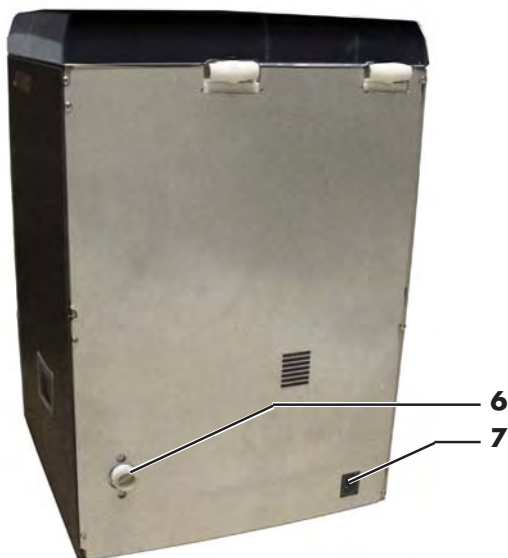
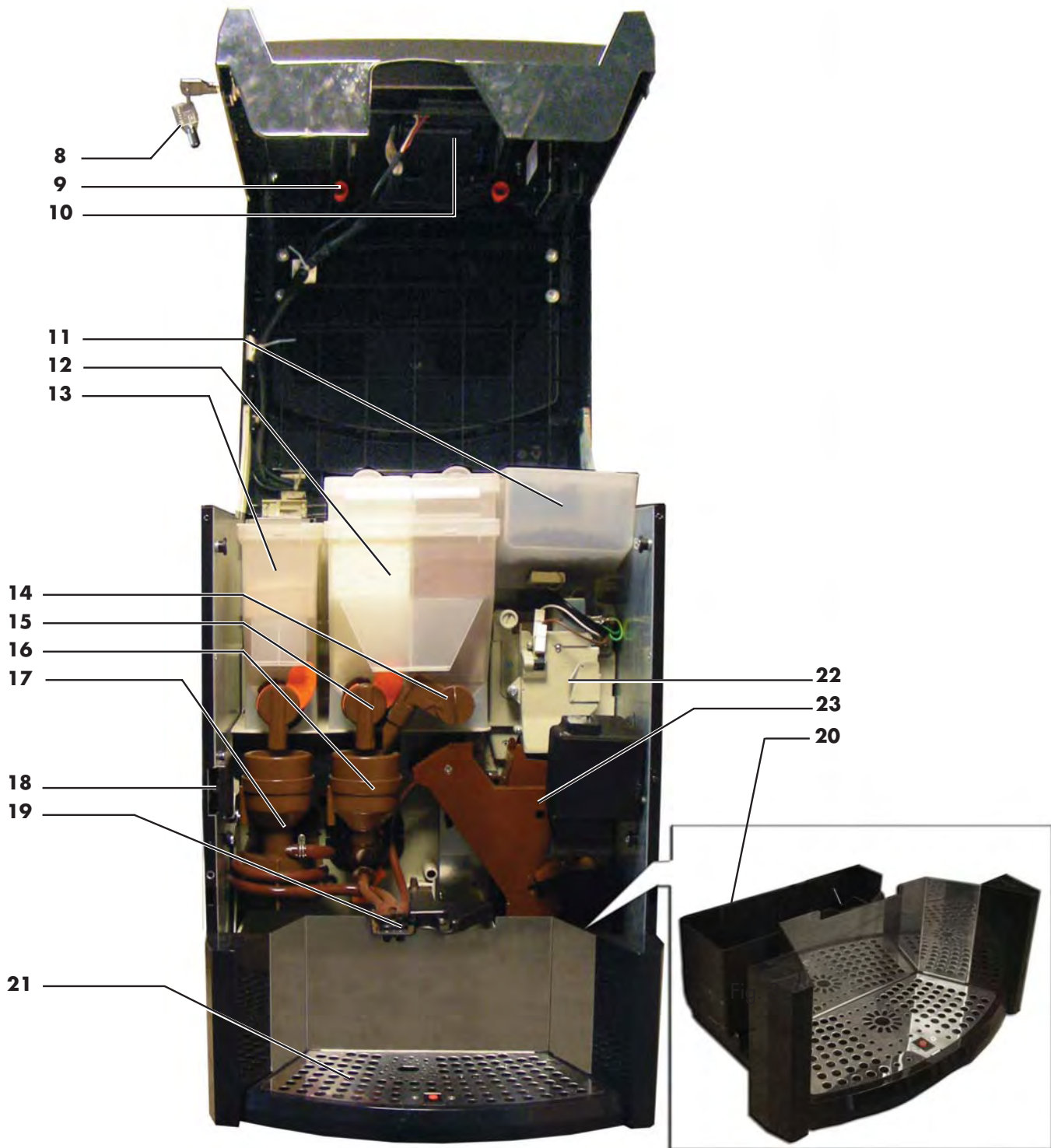

Fig. 2

- | | |
|----------|--|
| 1 | Top door |
| 2 | Display |
| 3 | Front door |
| 4 | Buttons |
| 5 | Dispensing outlet (beverage dispensing) |
| 6 | Coupling for connection to water network |
| 7 | Power cord outlet |



- | | | | |
|-----------|--------------------------------------|-----------|-----------------------|
| 8 | Door lock | 16 | Mixer |
| 9 | Front door fastener knob | 17 | Spiral mixer |
| 10 | CPU electronic board | 18 | Safety switch |
| 11 | Coffee bean hopper | 19 | Brewing arm |
| 12 | Container 2/3 (instant products) | 20 | Coffee grounds drawer |
| 13 | Container 1 (instant products) | 21 | Grill |
| 14 | Adjustable powder dispensing channel | 22 | Coffee grinder |
| 15 | Instant product dispenser | 23 | Brew group |

MAIN PARTS - INSTANT VERSION

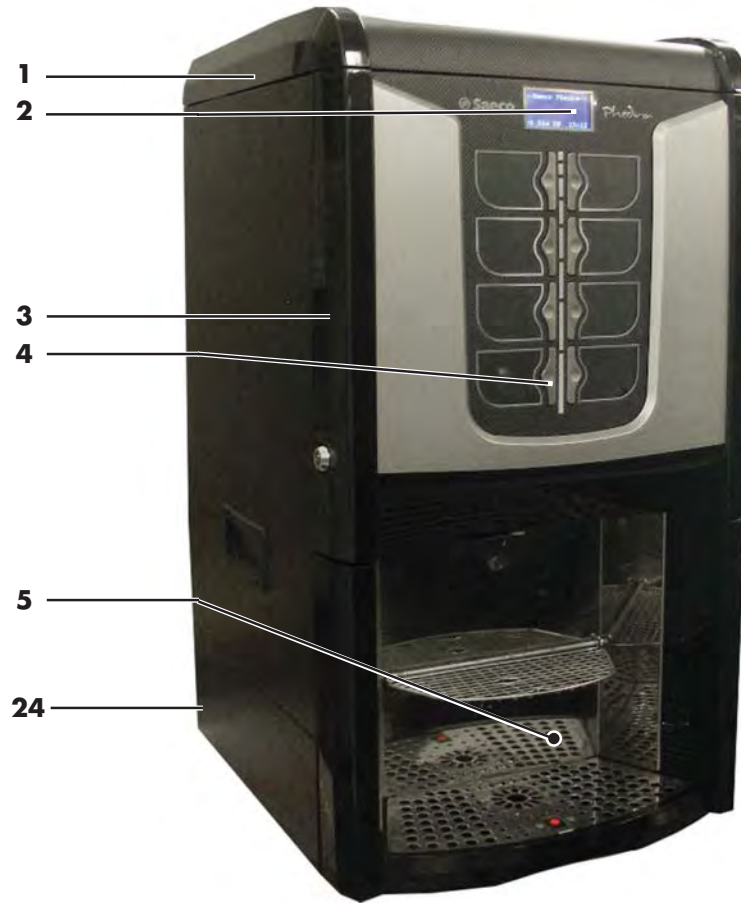

Fig. 1



Fig. 2

- 1** Top door
- 2** Display
- 3** Front door
- 4** Buttons
- 5** Dispensing outlet (beverage dispensing)
- 6** Coupling for connection to water network
- 7** Power cord outlet
- 24** Extension (option)

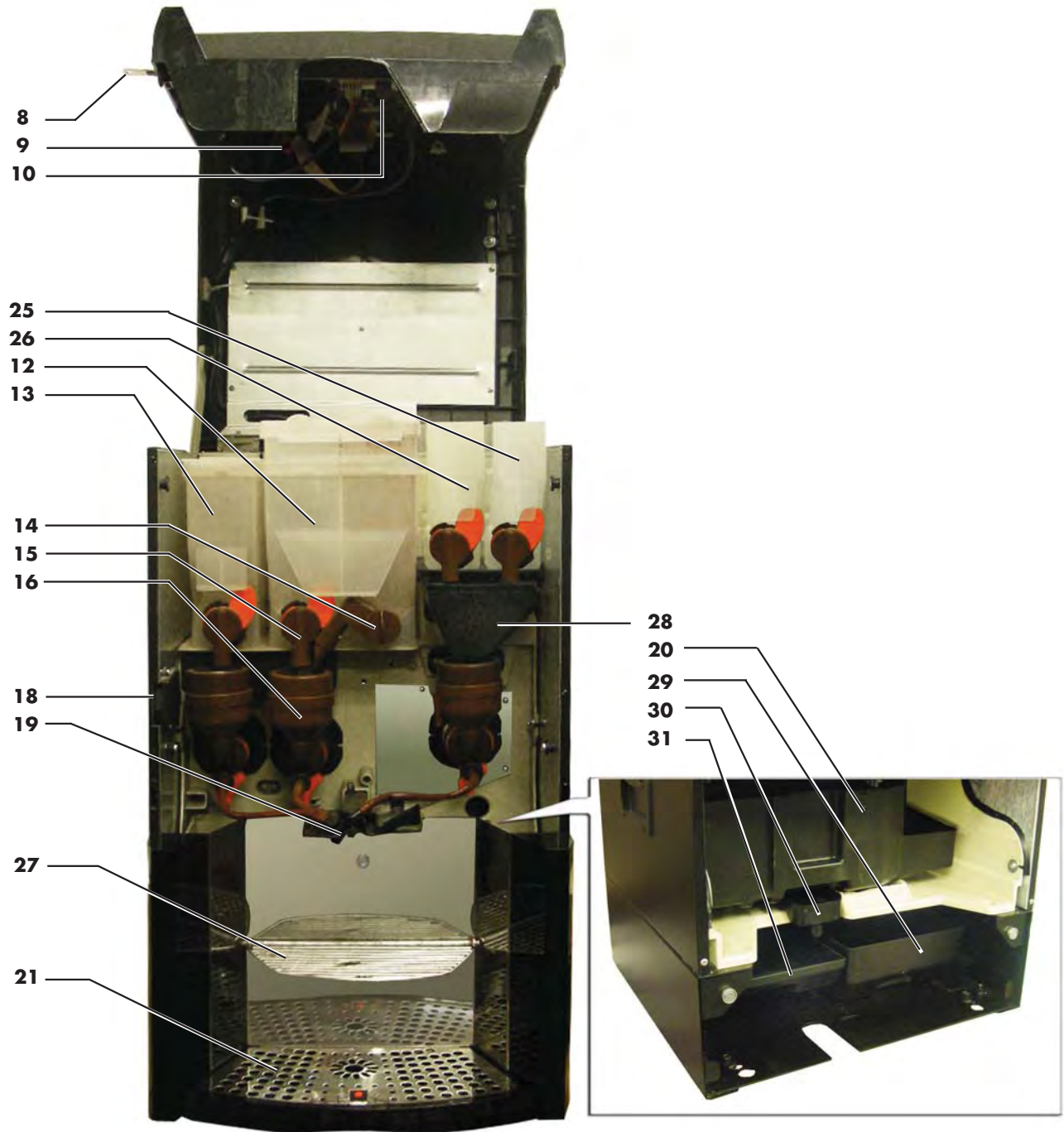

Fig. 3

- | | | | |
|-----------|--------------------------------------|-----------|---|
| 8 | Door lock | 20 | Coffee grounds drawer |
| 9 | Front door fastener knob | 21 | Grill |
| 10 | CPU electronic board | 25 | Container 5 (instant products) |
| 12 | Container 2/3 (instant products) | 26 | Container 4 (instant products) |
| 13 | Container 1 (instant products) | 27 | Grill for extension (option) |
| 14 | Adjustable powder dispensing channel | 28 | Powder diverter for small-type containers |
| 15 | Instant product dispenser | 29 | Coffee grounds drawer (option) |
| 16 | Mixer | 30 | Drip conveyor (option) |
| 18 | Safety switch | 31 | Drip tray (option) |
| 19 | Brewing arm | | |

MAIN PARTS - T.T.T. VERSION



Fig. 1

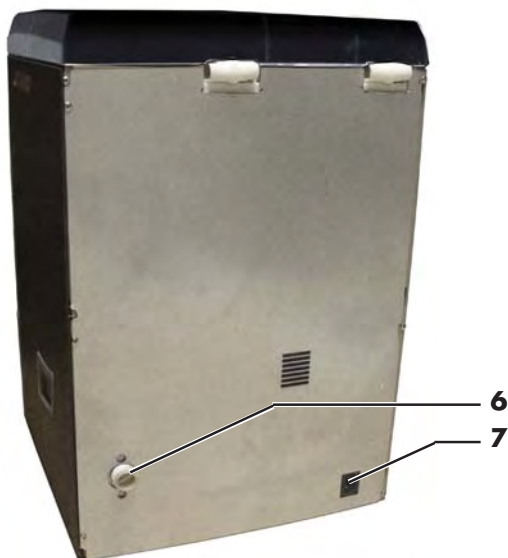
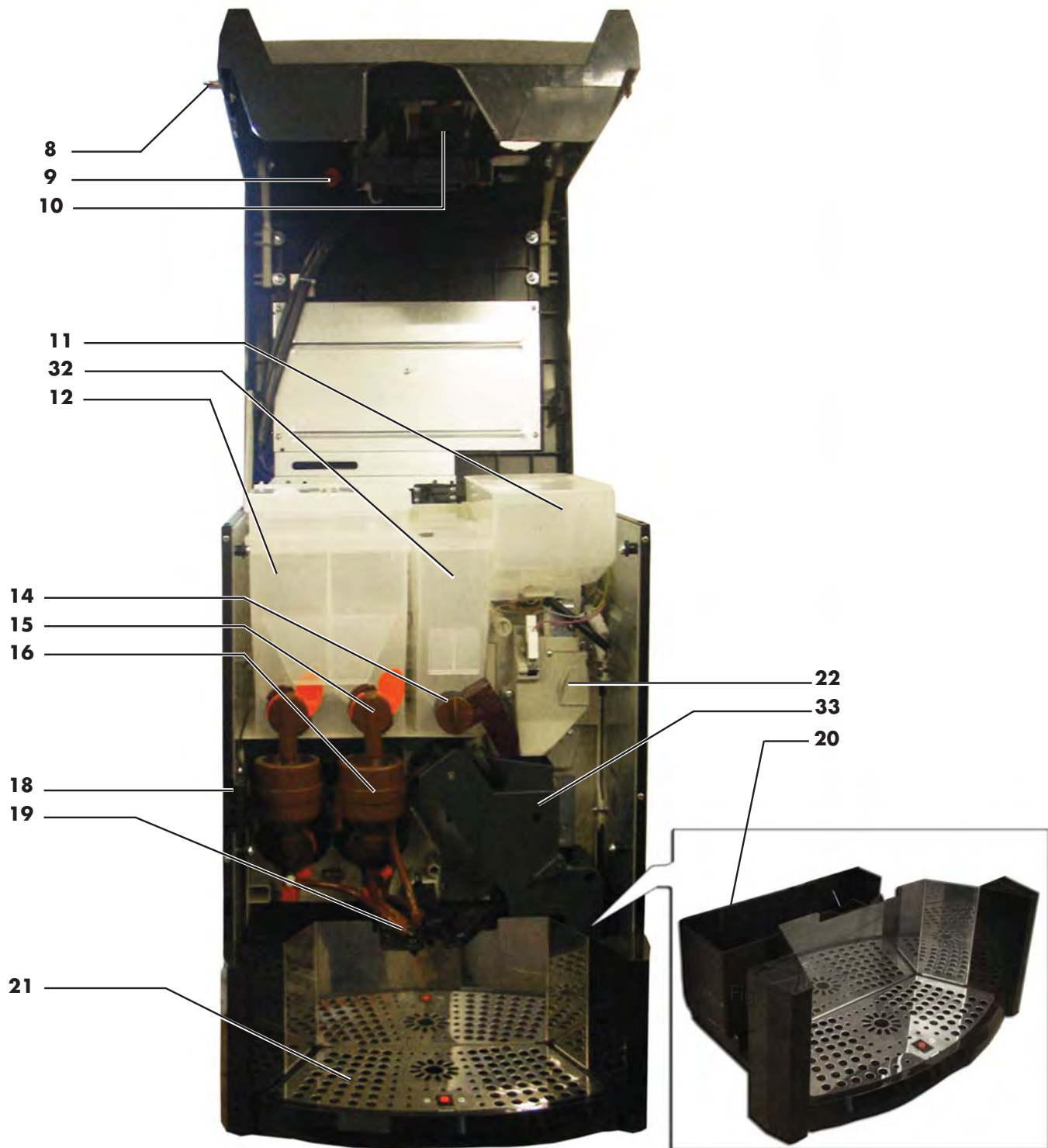

Fig. 2

- 1** Top door
- 2** Display
- 3** Front door
- 4** Buttons
- 5** Dispensing outlet (beverage dispensing)
- 6** Coupling for connection to water network
- 7** Power cord outlet



- 8** Door lock
- 9** Front door fastener knob
- 10** CPU electronic board
- 11** Coffee bean hopper
- 12** Container 1/2 (instant products)
- 14** Adjustable powder dispensing channel
- 15** Instant product dispenser
- 16** Mixer

- 18** Safety switch
- 19** Brewing arm
- 20** Coffee grounds drawer
- 21** Grill
- 22** Coffee grinder
- 32** Container 3 ("fresh brew" pre-ground coffee)
- 33** T.T.T. Brew group

MAIN PARTS - CAPPUCCINO VERSION

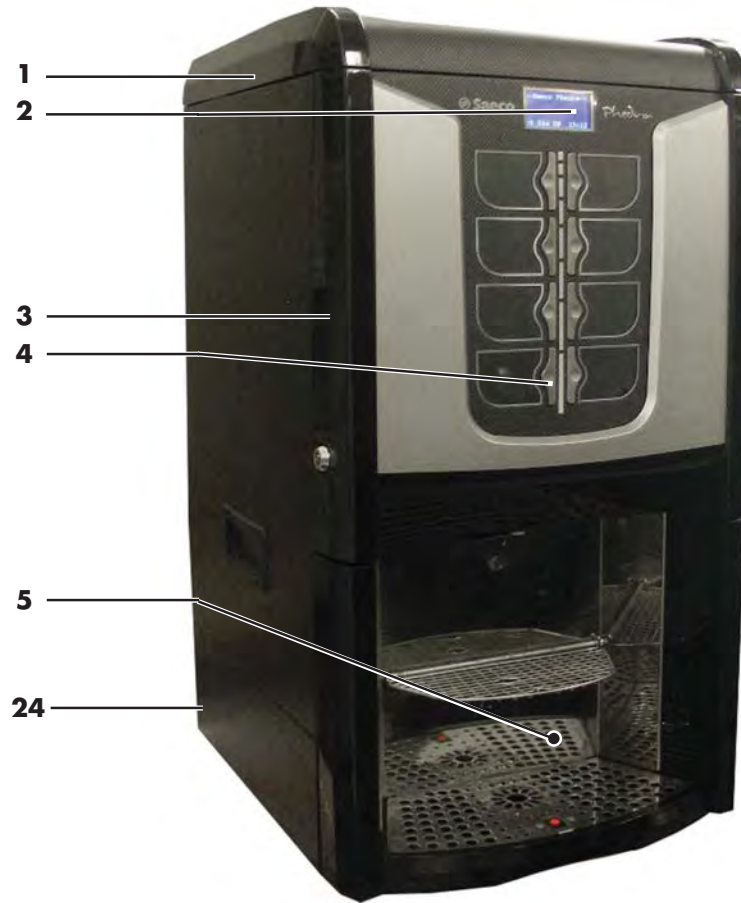

Fig. 1

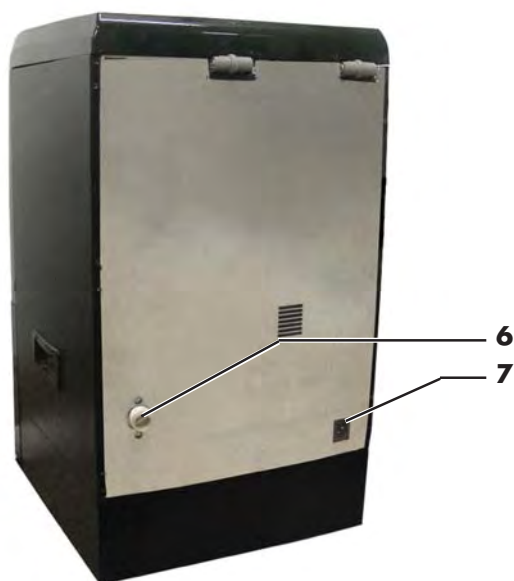

Fig. 2

- 1** Top door
- 2** Display
- 3** Front door
- 4** Buttons
- 5** Dispensing outlet (beverage dispensing)
- 6** Coupling for connection to water network
- 7** Power cord outlet
- 24** Extension (option)

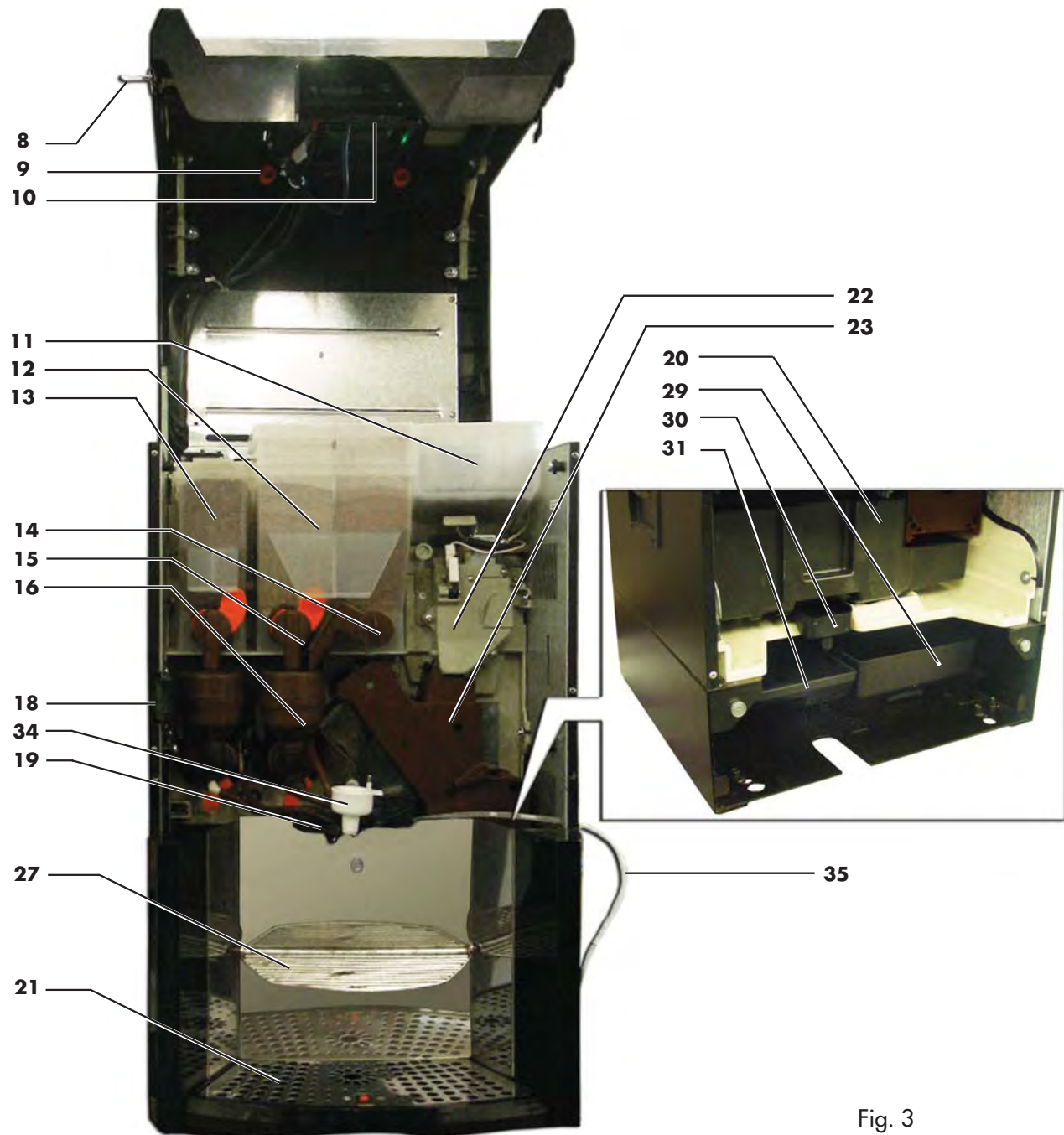

Fig. 3

- 8** Door lock
- 9** Front door fastener knob
- 10** CPU electronic board
- 11** Coffee bean hopper
- 12** Container 2/3 (instant products)
- 13** Container 1 (instant products)
- 14** Adjustable powder dispensing channel
- 15** Instant product dispenser
- 16** Mixer
- 18** Safety switch
- 19** Brewing arm

- 20** Coffee grounds drawer
- 21** Grill
- 22** Coffee grinder
- 23** Brew group
- 27** Grill for extension (option)
- 29** Coffee grounds drawer (option)
- 30** Drip conveyor (option)
- 31** Drip tray (option)
- 34** Cappuccinatore
- 35** Hose for Cappuccinatore

1 - INTRODUCTION TO THE MANUAL

1.1 Introduction



Important

This publication is an integral part of the vending machine and must be read carefully to ensure the machine is used correctly and in compliance with essential safety requirements.

This manual contains the technical information required for the correct use, installation, cleaning, and maintenance of the vending machine model **PHEDRA**. Always refer to this publication before carrying out any operation.

Manufacturer: **SAECO Vending S.p.A.**
Località Casona, 1066 - 40041 Gaggio Montano
Bologna, Italy

This publication should be kept carefully, together with the vending machine throughout its operational life, even in case of changes of ownership.

Should this manual be lost or worn out, a copy can be requested from the Manufacturer or an Authorized Customer Service Centre by indicating all data on the identification plate on the back of the vending machine.

1.2 Symbols used

This publication contains various warnings which indicate different degrees of danger or skills required.

The symbol is integrated with a message suggesting use procedures or actions and providing useful information for the correct operation of the machine.



Warning

Indicates dangerous situations for the users, supply operators and maintenance technicians dealing either with the vending machine or the product to be dispensed.



Important

Indicates the operations for keeping the vending machine in good working order.



Recommended solutions

Indicates alternative procedures that make the programming and/or maintenance operations quicker.



User

Indicates the user of the vending machine. This person is not authorized to carry out any cleaning or maintenance operation.



Supply operator

Indicates operations to be carried out only by personnel in charge of supplying and cleaning the vending machine. Maintenance operations requiring a Maintenance Technician are not to be performed by the supply operator.



Maintenance Technician

Indicates operations to be carried out by qualified personnel in charge of maintenance. The Maintenance Technician is the only person authorized to keep the MICROSWITCH ENABLING KEY, by which the security systems can be disabled.

2 - INFORMATION ON THE VENDING MACHINE

2.1 Information for the Maintenance Technician

The vending machine must be installed in a well-lit, dry and not dusty area, protected from exposure.

To guarantee the correct operation and reliability over time, the following is recommended:

- ambient temperature: from +1°C to +32°C;
- maximum humidity: 90% (not condensed).

For special installations not covered in this publication, please contact the dealer or the local importer. If this is not possible, please contact the Manufacturer directly.

AUTHORIZED CUSTOMER SERVICE CENTRES are available for information and explanations about the vending machine, and to provide technical assistance or spare parts.

The Maintenance Technician must carefully read and respect the safety warnings contained in this manual so that every intervention concerning installation, starting up, use and maintenance will be safely carried out.

It is the Maintenance Technician's absolute responsibility to give the keys to access the inside of the vending machine to another operator (Supply Operator), provided that the Maintenance Technician bears full responsibility for all work carried out.

This manual is an integral part of the machine and must be always read carefully before performing any operation.

2.2 Description and intended use

The vending machine is intended for automatic distribution of coffee and hot beverages (decaffeinated coffee, cappuccino, chocolate, etc.) and is programmable for every single type of dispensing dosage. The instant products must be consumed immediately, and cannot be preserved for a long time.

Any other use is to be considered improper and therefore dangerous.

Do not place any product inside the distributor which may be dangerous as a result of unsuitable temperatures.

With reference to the definition of "professional appliance" given by the standard EN60335-2-75 for vending machines, this appliance can not be classed as professional.

Important

Improper use of the vending machine invalidates all warranties. The Manufacturer declines any liability for damage to property or injury to persons.

Improper use also includes:

- any use of the vending machine other than the intended use and/or according to procedures which are not described in this publication;
- any intervention on the vending machine which differs from the instructions given in this publication;
- any alteration of components and/or safety devices without prior consent of the Manufacturer or carried out by personnel not authorized for such operations;
- any location of the appliance which is not recommended in this manual.

2.3 Vending Machine Identification

The vending machine is identified by the name, model and serial number which can be found on the relevant data plate (Fig. 4).

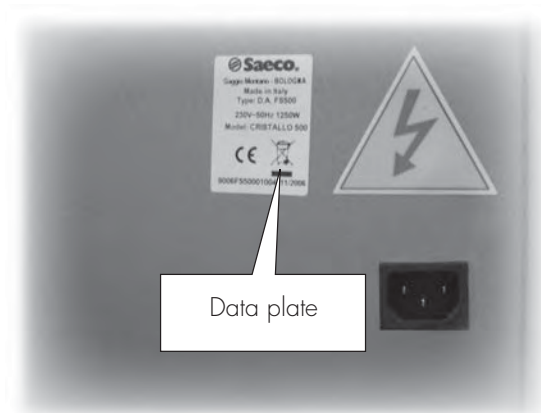

Fig. 4

The following data can be found on the plate:

- name of Manufacturer;
- marks of compliance;
- model;
- serial number;
- year and month of manufacture;
- supply voltage (V);
- supply frequency (Hz);
- electrical power consumption (W).



Warning

It is strictly forbidden to tamper with or modify the data plate.



Important

When contacting the AUTHORIZED CUSTOMER SERVICE CENTRES always refer to this plate and its relevant data.

2.4. Technical specifications



Height:	594 mm standard 714 mm with extension
Width:	394 mm
Depth:	430 mm
Weight:	31 kg Espresso 35 kg Instant with extension 31 kg T.T.T. 38 kg Cappuccino with extension
Power consumption:	see data plate
Supply voltage:	see data plate
Electric voltage frequency:	see data plate
Power cord length:	1,600 mm
Water mains connection:	3/4" Gas type
Water mains pressure:	see figure 6



Fig. 6

Container capacity

Coffee beans:	1,00 kg
Chocolate:	1,75 kg
Milk:	0,65 kg
Lemon tea:	1,50 kg
Ginseng:	double: 1,85 kg, standard: 1,15 kg
Ground coffee:	0,62 kg
Freeze-dried coffee:	standard: 0,41 kg, small: 0,23 kg
Barley:	standard: 0,36 kg, small: 0,20 kg

3 SAFETY

3.1 Introduction

In compliance with the Low Tension Directive 2006/95/EC (which replaces the directive 73/23/EEC and following amendments) and CE Marking Directive 93/68/EEC, **SAECO VENDING** has drawn up a technical file of the **PHEDRA** vending machine held at its plants. The following regulations were taken into account during the design phase:

- EN 55014
- EN 61000-3-2
- EN 61000-3-3
- EN 61000-4-2
- EN 61000-4-3
- EN 61000-4-4
- EN 61000-4-5
- EN 61000-4-11
- EN 60335-2-75
- EN 60335-1

3.2 General safety regulations

It is forbidden to:

- tamper with or disable the safety systems installed on the vending machine;
- carry out maintenance on the vending machine without unplugging it first;
- install the vending machine outdoors. It should be placed in dry areas where the temperature never falls below 1°C;
- use the vending machine for purposes other than those indicated in the sale contract and in this publication;
- connect the appliance to the mains using multi-sockets or adapters;
- use water jets to clean the vending machine (Fig. 6).



Fig. 7

It is compulsory to:

- check the electrical power line for conformity;
- use original spare parts;
- read the instructions contained in this publication and in the enclosed documents carefully;
- use personal protection devices during installation, testing and maintenance operations.

Precautions for preventing human errors:

- make the operators aware of safety issues;
- handle the vending machine, either packaged or unpackaged, in safe conditions;
- have a thorough knowledge of the installation procedures, its operation and limits;
- dismantle the vending machine in safe conditions, in accordance with the environmental protection and health and safety laws in force.



Warning

In case of failure or malfunctioning contact only qualified CUSTOMER SERVICE personnel.



Important

The Manufacturer declines any liability for any damage caused to property or injury caused to persons as a result of failure to observe the safety regulations described here.



Important

This appliance is not intended for use by persons (including children) with reduced physical, sensory or mental capabilities, or lack of experience and knowledge, unless they have been given supervision or instruction concerning use of the appliance by a person responsible for their safety.

3.3 Operators' requirements

Three operators with different skills are required in order to guarantee the safety of the vending machine:



User

Access to the internal part of the vending machine is forbidden to the user.



Supply operator

The Maintenance Technician assigns the safekeeping of the access key to the Supply operator who is in charge of product supply, external cleaning, and starting up / stopping of the vending machine.



Warning

The Supply Operator is not authorized to carry out operations which are indicated as being the duties of the Maintenance Technician in this publication.



Maintenance Technician

The Maintenance Technician is the only person authorized to intervene and start programming procedures, and perform adjusting, setting up and maintenance operations on the vending machine.

3.4 Safety devices

The vending machine is equipped with:

- A microswitch (Ref. 18, Fig. 8) automatically cuts out the power supply when the front panel is opened. The microswitch can be disabled by inserting the key (Ref. 24, Fig. 8).
- A microswitch (Ref. 25, Fig. 8) blocks vending machine operation when the drip tray and/or coffee grounds drawer are not correctly positioned. A message indicating the incorrectly positioned part appears on the display.

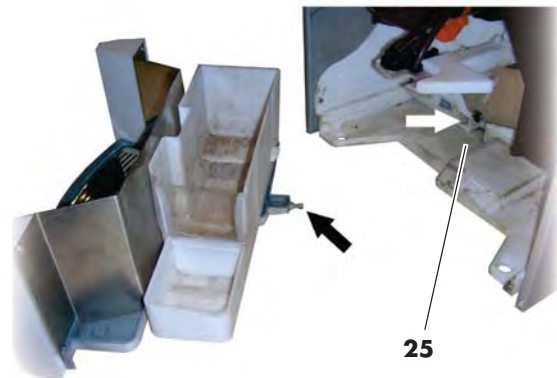
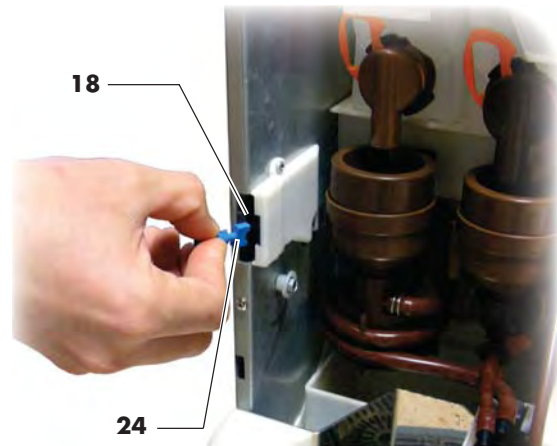

Fig. 8



Maintenance Technician

In case of programming or setting up operations only the Maintenance Technician can intervene by inserting the relevant key into the safety switch (rif. 24, fig. 8) and resetting the voltage even if the door is open.



Warning

This operation, necessary for starting up the vending machine, disables the safety system. It must therefore be carried out by qualified personnel (Maintenance Technician) aware of the risks resulting from the presence of live or moving components.

3.5 Residual risks



Warning

Risk of scalding if hands are placed inside the outlet during brewing.

Do not remove the cup or put your hands inside the compartment during beverage brewing before the brewing cycle has finished.

Before removing the cup from the outlet, please wait for the message "REMOVE CUP" on display.



Important

Before brewing another beverage, check that the previous one has been taken out and that the cup support is empty.

4 - HANDLING AND STORAGE

4.1 Unloading and handling

Unloading and handling operations after transportation must be carried out only by qualified personnel and using suitable equipment.



Warning

The vending machine must always be kept in the upright position. Avoid:

- dragging the vending machine;
- overturning or laying the vending machine flat during transport and handling;
- shaking the vending machine;
- leaving the vending machine exposed to the elements, in humid areas or close to heat sources.

4.2 Storage

If the vending machine is not installed immediately, it should be stored in a sheltered area, conforming to the following instructions:

- the packaged vending machine must be stored in a closed, dry area at a temperature between 1°C and 40°C;
- do not put other appliances or boxes on the vending machine;
- it is always good practice to protect the vending machine from any deposits of dust or other material.

5 - INSTALLATION

5.1 Important



Warning

The vending machine cannot be installed outdoors; avoid placing it in areas where the temperature is less than 1°C or more than 32°C and in particularly damp or dusty areas.

Before unpacking, check that the installation area complies with the following specifications:

- the power socket must be located in an easily accessible area, not more than 1.5 meters away;
- the socket voltage must comply with that on the identification plate;
- the surface or floor must NOT have a gradient of more than 2°.

If the vending machine needs to be positioned close to a wall, it is necessary to leave a space of at least 15 cm between the back and the wall in order to keep the air outlet grille free (Fig. 9).

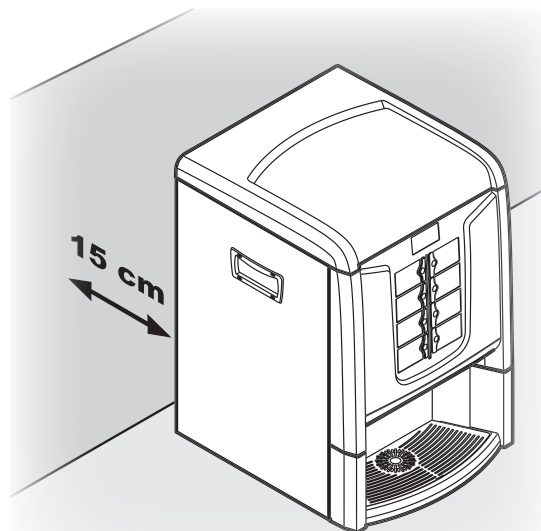

Fig. 9

5.2 Unpacking and positioning



On receipt of the vending machine make sure that it has not been damaged during transportation and that package has not been tampered with or that internal parts have not been removed.

An envelope, called "CUSTOMER KIT" is supplied with the vending machine; it contains the objects shown in Fig. 10.

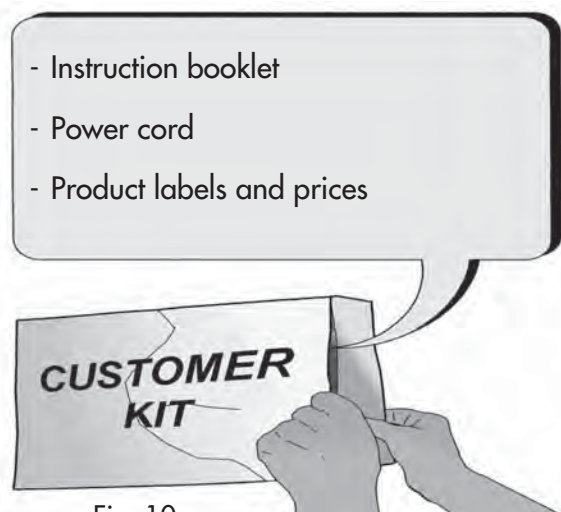

Fig. 10

The vending machine is protected by an expanded polyethylene foam sheet and a plastic bag inside a box (Fig. 11).

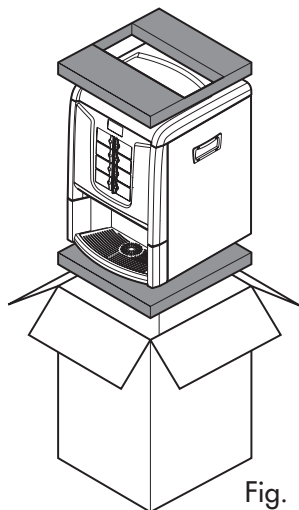

Fig. 11

If damage of any kind is found, the courier must be informed and notice must be given to the importer or the seller immediately. If these are not in the purchaser's country, please contact the manufacturing company directly.

The accessory bag contains:

- 1 key for the brew group;

5.3 Label application

Product labels

Open the vending machine. Insert the product labels (Fig. 12).



Fig. 12

Check the exact position of the labels against the selection key (Fig. 13a, 13b, 13c, 13d).



Espresso version

Fig. 13a



Instant version

Fig. 13b



Cappuccino version

Fig. 13d



T.T.T. version

Fig. 13c

5.4 Fitting the payment systems



Important

The vending machine is not supplied with any payment system, which must be installed by the person in charge of its fitting.

The vending machine is designed for the installation of various payment systems, such as:

- Parallel coin validator, 24 V DC
- Cashless reader (EXECUTIVE, PRICE HOLDING, MDB, and BDV systems)



Fig. 14



Important

After the chosen payment system has been installed, the corresponding parameters can be set through the programming menu (see 8.2).



Warning

The Manufacturer declines any liability for any damage to the vending machine, to property and/or injury to persons, caused by the installation of the payment system. The responsibility falls to the person who carried out the installation.

5.5 Connection to water mains



Important

The pressure reducer is calibrated during assembly. Should problems occur with the calibration of the pressure reducer, the outlet pressure value must absolutely be reset to 0.8 – 1 bar max. Different or approximate calibration may cause product quality and quantity variations when brewed.



Important

It is recommended to use a descaling device for the water network supplying the vending machine, especially for water with a high calcium and magnesium content (hard water). Connect the vending machine to a drinking water supply pipe with a pressure ranging between 1.5 and 8 bars (see data plate).



Important

Before connecting the appliance to water network, please read and follow the applicable regulations in force in your country.

Remove the cap from the coupling placed on the vending machine back panel (Fig. 15). Connect the water supply pipe to the 3/4" Gas coupling of the vending machine (Fig. 15).



Fig. 15

5.6 Connection to the electric network



Warning

The Maintenance Technician, who is responsible for the installation of the vending machine, must ensure that:

- the electric system complies with current safety regulations;
- the supply voltage corresponds to that indicated on the data plate.

If in doubt, do not proceed with the installation and ask qualified and authorized personnel to check the system accurately.

The vending machine is equipped with a power cord which must be plugged into the appropriate socket on the vending machine back panel (Fig. 16).



Fig. 16

Do not use adapters or multi-sockets (Fig. 17).



Fig. 17

5.7 Coffee Grounds Discharge Setting

The appliance is setup for direct discharge of the coffee grounds into the bag in the dedicated cabinet or into another container located below the appliance (ex. bar counter).

For this setting, the plate (Ref. A, Fig. 18) and coffee grounds drawer (Ref. A, Fig. 19) must be cut along the indicated marks.

Remove the tab the coffee grounds drawer hooks to (Ref. B, Fig. 19) using a cutter or a jigsaw.

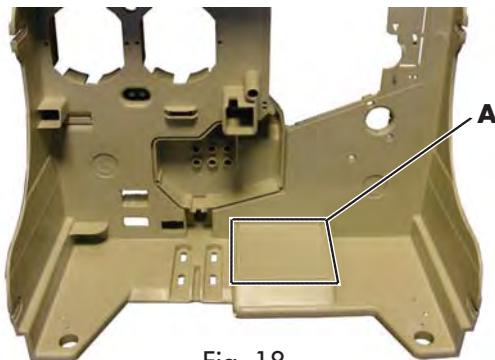

Fig. 18

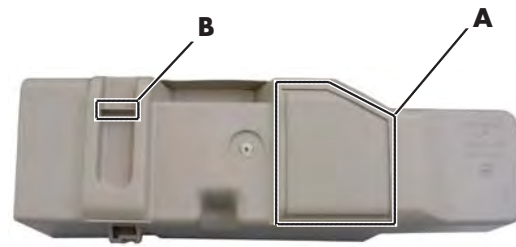

Fig. 19



Important

The appliance has an alarm signal to indicate when to empty the coffee grounds in the standard version. For this setting it is necessary to exclude this counter using the menu.

5.8 Liquid Drain Setting

The appliance is setup for direct drainage of the drip tray into container in the dedicated cabinet or into another container located below the appliance.

To use this setting, cut (or drill a hole in) the panel in the indicated area (Ref. A, Fig. 20).

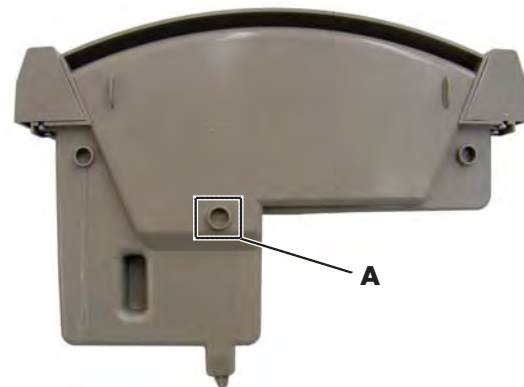

Fig. 20

5.9 Drip Tray Locking

Important

This option can be used to guarantee the appliance additional safety.

It is possible to block the removal of the drip tray without opening the door.

To use this option, remove the two locking pins integrated on the drip tray (Ref. A, Fig. 21).

Divide them and, after trimming them with a cutter, glue them on the two studs (Ref. A, Fig. 22) located on the lower front part of the drip tray (thus lengthening the centring pieces).

In this manner, it will no longer be possible to remove the drip tray without first opening the door.



Fig. 21

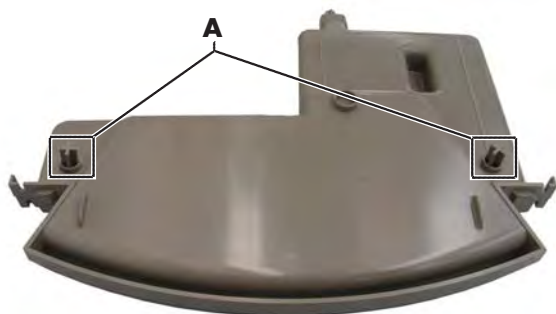

Fig. 22

5.10 Front Door Intermediate Locking

In order to perform an unscheduled maintenance lock the front door as shown in Fig. 23.



Fig. 23

This is possible after opening the vending machine, by turning the key clockwise and fitting the slots (Ref. A, Fig. 24) on the pins (Ref. B, Fig. 24).

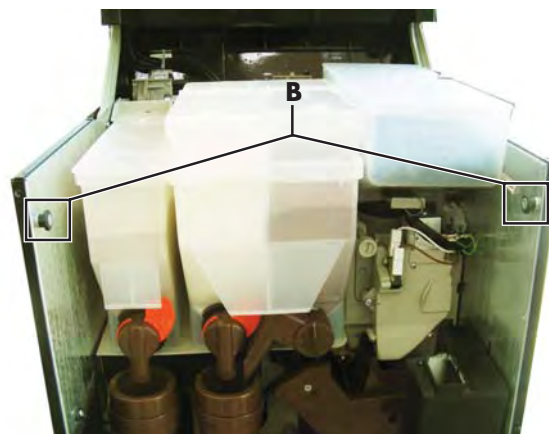

Fig. 24

6 - CONTROLS DESCRIPTION

6.1 Display

The display (2 - Fig. 1) shows the messages during standard operation, programming and maintenance modes.

6.2 Keypad

Important

Each key function changes according to the vending machine mode (ordinary dispensing or programming mode).

Each key has a double function that varies according to the vending machine status (standard operation or programming).

6.3 Key description in standard operation mode

Keys (1 to 8 - Fig. 25)

By pressing these keys, the programmed beverages are dispensed.

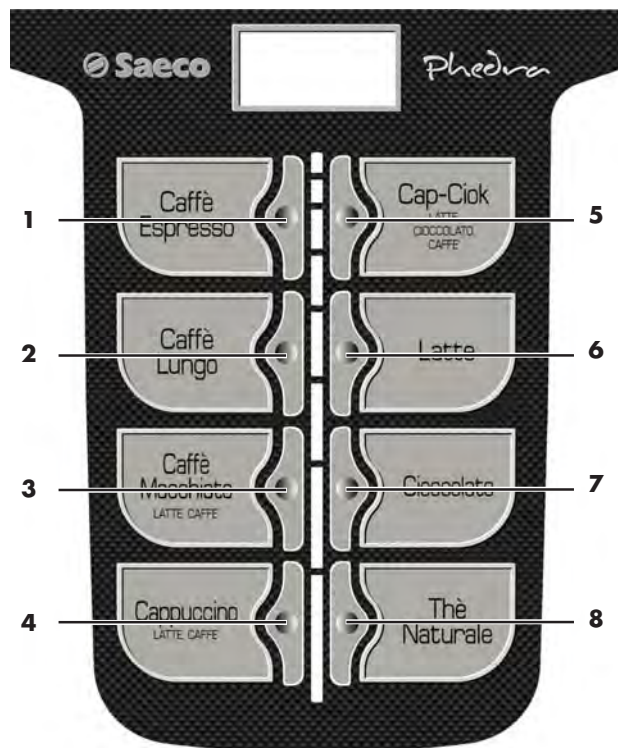

Fig. 25

6.4 CPU card keys



The CPU electronic card has 4 keys enabling the Maintenance Technician to carry out programming or maintenance operations (Fig. 26).



Fig. 26

7 - SUPPLY AND STARTING UP

7.1 Container supply (Espresso)



Important

The containers delivered are designed to dispense the following products (Fig. 27a):

Instant product 1 = Tea

Instant product 2 = Milk

Instant product 3 = Chocolate

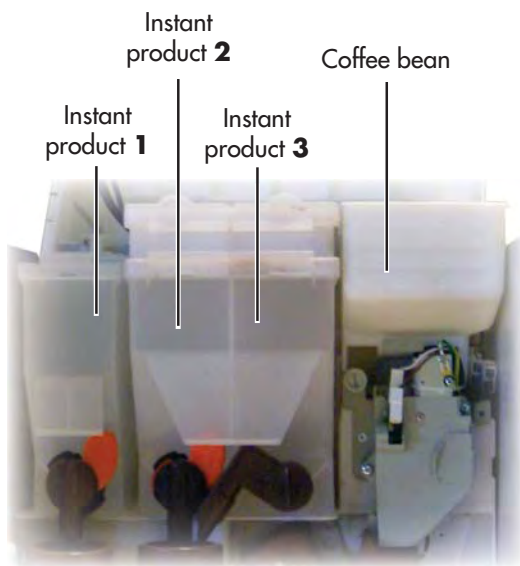

Fig. 27a

7.2 Container supply (Instant)



Important

The containers delivered are designed to dispense the following products (Fig. 27b):

Instant product 1 = Tea

Instant product 2 = Milk

Instant product 3 = Chocolate

Instant product 4 = Barley

Instant product 5 = Freeze-dried coffee

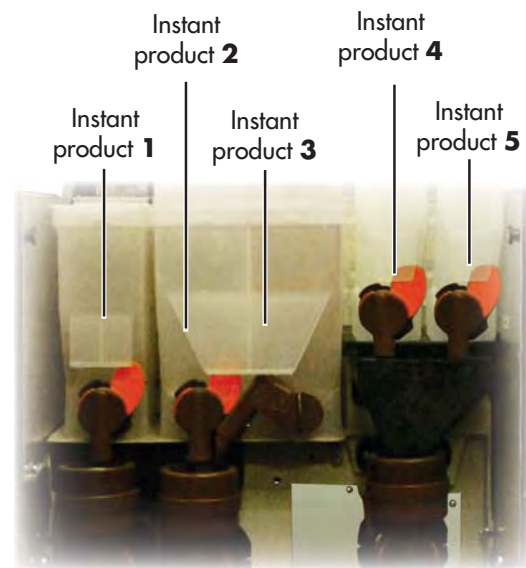

Fig. 27b

7.3 Container supply (T.T.T.)



Important

The containers delivered are designed to dispense the following products (Fig. 27c):

- Instant product 1** = Tea
- Instant product 2** = Milk
- Instant product 3** = Ground coffee

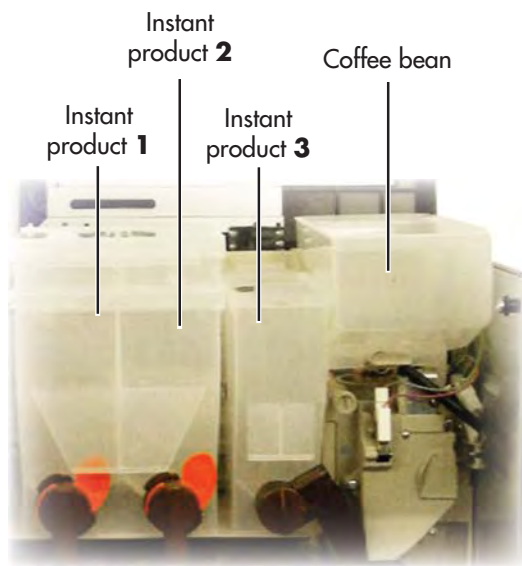

Fig. 27c

7.4 Container supply (Cappuccino)



Important

The containers delivered are designed to dispense the following products (Fig. 27d):

- Instant product 1** = Freeze-dried coffee
- Instant product 2** = Ginseng
- Instant product 3** = Chocolate

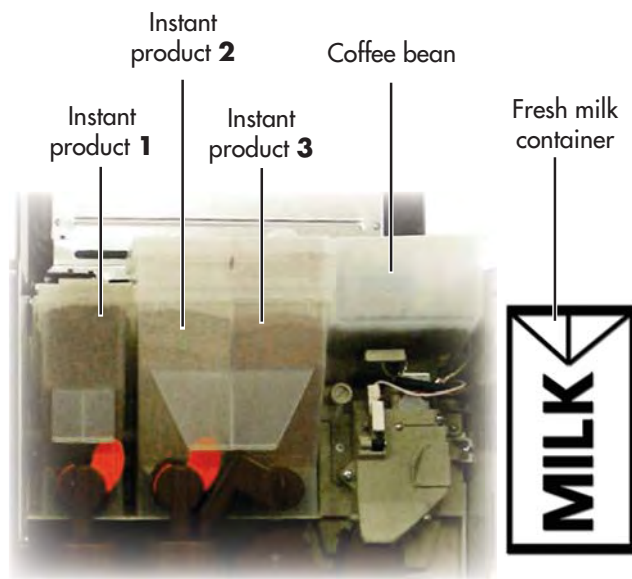

Fig. 27d

7.4.1 Coffee bean supply



Remove the container cover (Fig. 28).



Fig. 28

Put coffee beans into the container (Fig. 29).



Fig. 29

Replace the cover on the container.



Important

If the message "COFFEE NOT AVAILABLE" is displayed after the supply, the following operations should be carried out:

- press the "**P2**" key (Fig. 26) to enter the maintenance menu;
- press the key "**e**" twice (Fig. 36) to eliminate the error (see sect. 8.3.3 Description of messages in the maintenance menu).

7.4.2 Instant product supply



Open the cover of the container to be supplied (Fig. 30).



Fig. 30

Pour the instant product into the container (Fig. 31).



Fig. 31

Close the container cover.

7.5 Coffee grinding calibration



Turn the ring (Fig. 32) until the required results are obtained. After any calibration three selections are necessary before the new setting becomes effective.

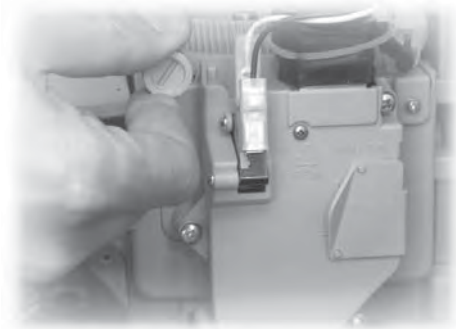

Fig. 32

7.6 Dose calibration



The vending machine is delivered with standard calibration values set by the manufacturer. The quantity of coffee powder is set to 7.0 gr.

Dose calibration can be performed by means of two calibration levels:

- remove the cover (Fig. 33);

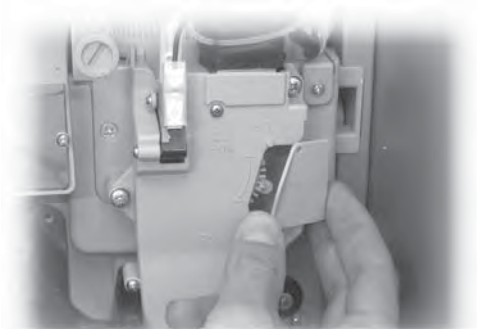

Fig. 33

- release the adjusting lever from the rack and place the dragging tooth of the inner panel on one of the 4 positions available, which indicate the basic quantity area (6 gr. - 7 gr. - 8 gr. - 9 gr.) (Fig. 34);

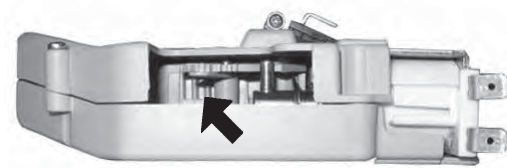

Fig. 34

- move the adjusting lever into the rack and select the slot corresponding to the dose required (Fig. 35).

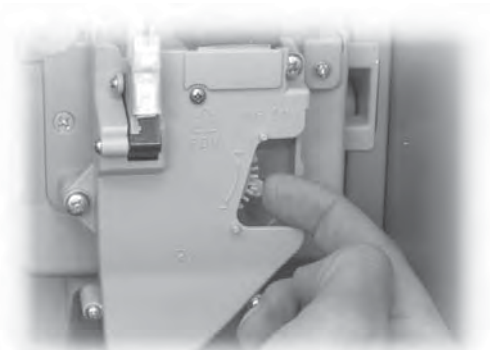

Fig. 35

7.7 First start-up of the vending machine



Supply the vending machine (following the instructions given previously) and plug it into the power supply (see 5.6).

At this point, the message "PHEDRA" appears on the display and the self-configuration is turned on.

Any faults detected during the self-configuration cycle are stored so that the vending machine can display them at the end of the self diagnostic phase.

Adjust grinding as instructed in 7.2; the boiler must be necessarily filled.

7.8 Filling the boiler manually



Manual filling of the boiler is required during the first start-up of the vending machine.

After switching on the vending machine, it is possible to fill the boiler by means of the following procedure:

- press the "**P2**" key (Fig. 26) to enter the maintenance menu;
- press the "**e**" key (Fig. 36) followed by the "**UP**" key (Fig. 36) to access the RINSING entry;
- press the "**e**" key (Fig. 36) to carry out the automatic complete rinsing cycle.
- repeat the washing operation until water comes out of the beverage dispensing nozzles.



Important

The rinsing operation must be repeated until water flows out of the brewing nozzles regularly.

7.9 Use of the vending machine



The beverage selection procedures are shown in section 9.

8 - PROGRAMMING AND MAINTENANCE MENU

Important

This section illustrates how to set up or modify the vending machine programming and maintenance settings.

It is therefore necessary to read it carefully, and intervene only when the correct sequence of operations to be performed is fully understood.

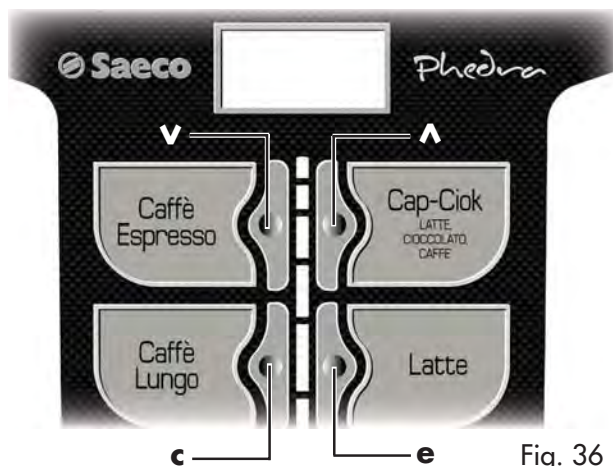

Fig. 36

8.1 Key description of programming and maintenance phases

To scroll through the vending machine menu, the keys described below are used.

“e” Key: ENTER (Fig. 36)

By pressing this key it is possible to enter the following programming or maintenance level. It is also possible to modify or confirm the values set in the entries of the programming or maintenance menus.

“c” Key: CANCEL (Fig. 36)

By pressing this key it is possible to go back to the previous level of the programming or maintenance menu. It is also possible to avoid storing the previously modified values.

“V” Key: DOWN (Fig. 36)

Pressing this key it is possible to access the previous entry inside the same level.

If used after a setting modification request, the value of this setting decreases.

“^” Key: UP (Fig. 36)

By pressing this key it is possible to access the next entry inside the same level.

If used after requesting the change of a setting, the value of this setting increases.

8.2 Programming menu

The structure of the programming menu is shown in 8.2.2. 8.2.3 describes all the entries in the programming menu.

8.2.1 Entering the programming menu

Open the door, disable the safety device (see 3.4) and press the “P1” key (Fig. 26) to enter the programming menu.

If no password has been assigned, the programming menu is entered directly.

Important

If a password was assigned to the vending machine to enable the programming menu, the message “PASSWORD 000000” will appear on the display with a flashing cursor on the first digit.

Now the password should be entered using the UP and DOWN keys. Confirm the digit entered by pressing the ENTER key.

Proceed as follows to exit the programming menu and return to standard operation of the vending machine:

- Press the ESC button repeatedly until “EXIT ?” appears. Select YES and press ENTER.
- remove the key from the safety switch in order to turn off the vending machine;
- close the door and wait for the self-configuration process to end.

8.2.2 Structure of the programming menu

1.	System manas.
1.1.	UMC code
1.2.	Stop
1.2.1.	Stop coffee
1.2.2.	Stop Presground
1.2.3.	Stop beverages
1.2.4.	CofGrounds contr
1.2.5.	Stop CofGrounds
1.2.6.	Reset
1.3.	Water filter
1.3.1.	Last filter change
1.3.2.	Remainins qty
1.3.3.	Filter limit
1.3.4.	Filter reset
1.3.5.	Filter enabled
1.4.	Boiler 1 Temp.
1.4.1.	Min temperature
1.4.2.	Max temperature
1.5.	Boiler 2 Temp.
1.6.	EnergySave
1.6.1.	Stand-By Timeout
1.6.2.	Eco Timeout
1.6.3.	Delta Temp. ECO
1.7.	PreHeat
1.7.1.	Coffee preheat.
1.7.2.	InstProd preheat
1.7.3.	Capp. PreHeat
1.8.	Steam Cleanins
1.8.1.	Steam clean time
1.8.2.	EnableSteamWash
1.9.	Rinse cycle
1.10.	Pre-grindins
1.11.	Program messages
1.11.1.	Stand-by
1.11.2.	Preselection
1.11.3.	Brewins
1.11.4.	Out of service
1.12.	Contrast
1.13.	Pulse counter
1.14.	Clock
1.14.1.	Time
1.14.2.	Date
1.15.	Multiple bever.
1.15.1.	Multiple bever.
1.15.2.	Enable MultBev
1.16.	Enable reset

1.17.	Free Prod button
1.18.	Presel. button
1.19.	Lanuaage
1.20.	Change Password
1.20.1.	Pros. password
1.20.2.	Service password
1.21.	On/Off time
1.21.1.	On 1
1.21.2.	Off 1
1.21.3.	On 2
1.21.4.	Off 2
1.22.	EVA-DTS
1.22.1.	EA1..2 (Events)
1.22.2.	EA3..5 (Readout)
1.22.3.	LA1-Prices Lists
1.22.4.	PA1..4 Products
1.22.5.	VA1..3 Sales
1.22.6.	BA1-CA15-Cash
1.22.7.	DA1..7-CashLess
1.23.	Audit Msa.Enable
1.24.	Ev Water Assian.
1.25.	Complete Menus
1.26.	VM Model
1.27.	Factory Default
1.28.	System Info
2.	Payment system
2.1.	Protocol
2.2.	Parallel coiner
2.2.1.	Enable
2.2.2.	Coin values
2.3.	Banknote reader
2.3.1.	Enable
2.3.2.	Inhibition level
2.3.3.	Banknote values
2.4.	MDB settins
2.4.1.	Recharge enabled
2.4.2.	Max CardRecharge
2.4.3.	Max card charge
2.4.4.	Coins enablins
2.4.5.	Alt. payout
2.4.6.	Max change
2.4.7.	Exact change
2.4.8.	Min tube level
2.4.9.	Tube fillins
2.4.10.	Tube emptyins
2.4.11.	Commit to vend

2.4.12.	Banknote enabl.
2.4.13.	Banknote escrow
2.4.14.	Slave address
2.5.	Max credit
2.6.	Multivend
2.7.	Overpay time
2.8.	Fixed zeros
2.9.	Decimal disits
3.	Product setup
3.1.	Prod. before
3.1.1.	Instant Product
3.1.2.	Instant Product
3.1.3.	Instant Product
3.1.4.	Instant Product
3.1.5.	Instant Product
3.2.	Beverase enabled
3.3.	Beverase brewins
4.	Sales management
4.1.	Price table
4.1.1.	Price (1-100)
4.2.	Beverase prices
4.2.1.	Normal
4.2.2.	Diff 1
4.2.3.	Diff 2
4.2.4.	Card
4.3.	Free
4.4.	Free on
4.5.	Free off
4.6.	Diff Prices 1-On
4.7.	DiffPrices 1-Off
4.8.	Diff Prices 2-On
4.9.	DiffPrices 2-Off

8.2.3 Description of messages in the programming menu

SYSTEM MANAGEMENT

```
1.
System manas.
...
```

The SYSTEM MANAGEMENT items are:

```
1.1.
VMC code
531000
```

VM Code

Enables an identification code to be assigned to the vending machine.

```
1.2.
Stop
...
```

Stops

Enables setting of the maximum amount of beverage or coffee. Once the maximum amount is reached, the vending machine stops dispensing the relevant beverages.

```
1.2.1.
Stop coffee
0
```

STOP COFFEE

Enables setting of the maximum number of coffee cups to be dispensed before the stop.

```
1.2.2.
Stop preground
```

BLOCCO PREGOUND

It allows setting the maximum number of beverages with pre-ground coffee to be brewed before stopping the pre-ground products.

```
1.2.3.
Stop beverages
```

STOP BEVERAGES

Enables setting of the maximum number of beverages to be dispensed before the stop.

```
1.2.4.
CofGrounds contr
Yes
```

COFGROUNDS CONTR

Enables or disables control of the number of grounds discharged into the coffee

grounds drawer.

When set to "YES" the machine will allow a certain number of cups of coffee to be brewed before requiring the drawer to be emptied (see "STOP COFGROUNDS").

When set to "NO" the machine will not control the number of grounds discharged into the drawer.

```
1.2.5.
Stop CofGrounds
00
```

STOP GROUNDS

It allows you to set the maximum number of coffee cups to be brewed, corresponding to

maximum dump box capacity. Once reached the set quantity, coffee-based beverages dispensing is stopped.

Five cups of coffee before the lock is engaged, a blinking message appears on the display, "EMPTY COFGROUNDS".



Important

This lock can be reset by removing the coffee grounds drawer for at least 10 seconds.



Recommended solutions

It is advisable to set a max. of 30 coffees when using the dump box supplied with the machine



Important

Do not set any stop value if you are using the machine together with the supporting cabinet, which is equipped with its own dump box which is not controlled electronically

```
1.2.6.
Reset
...
```

RESET

Enables resetting of all partial counters relative to product quantity stop functions.

```
1.3.
Water filter
...
```

Water Filter

(Only if Complete Menus are enabled) Allows the use of the water filter to be checked.

```
1.3.1.
Last filter change
31 sen 08
```

LAST FILTER CHANGE

Date of the last filter reset.

```
1.3.2.
Remaining qty
95
```

REMAINING QTY

Number of litres of water that can still be dispensed before the filter needs to be regenerated. When this value is less than 1, a Warning (W83) is recorded in the Error LOG.

```
1.3.3.
Filter limit
100
```

FILTER LIMIT

Number of litres of water that can still be dispensed from the filter.

```
1.3.4.
Filter reset
```

FILTER RESET

Select YES to indicate a new filter has been installed. This operation returns "Remaining Qty" to the same value as "Filter Limit" and the date in the "Last Filter Change" is changed to today's date.

```
1.3.5.
Filter enabled
si
```

FILTER ENABLED

Enables management of the "Remaining Qty" countdown.



Important

From the maintenance menu (button P2 on the CPU), you can access "Water Filter", "Last Filter Change", "Remaining Qty" and "Filter Reset".

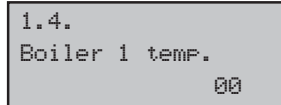

Boiler 1 temperature
According to the model, the Phedra vending machine may be equipped with 1 or 2 boilers. The following table matches the boilers with the vending machine models.

Model	Boiler 1	Boiler 2
Espresso	Beverage and coffee boiler	Not present
Instant	Beverage boiler	Beverage boiler
T.T.T.	Beverage and coffee boiler	Not present
Cappuccino	Beverage and coffee boiler	Steam boiler

This menu option allows setting the operating temperature of boiler 1.

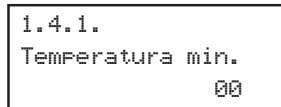

MIN. TEMPERATURE
Enables setting of the temperature to be maintained for a few minutes by the vending machine after a beverage has been dispensed. The set value is expressed in centigrade.

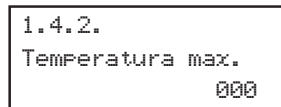

MAX. TEMPERATURE
Enables setting of the temperature to which the vending machine is brought after a certain time from the last dispensing, in order to compensate for the natural decrease of the temperature of the hydraulic circuits. The set value is expressed in centigrade.

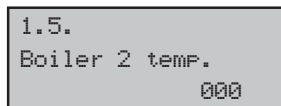

Boiler 2 temperature
This menu allows setting the operating temperature for boiler 2.

This setting is not used for the boiler of the Instant version and in case the boiler 2 is not installed.

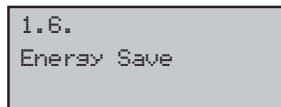

Energy Save
The "Stand-by" and "ECO" modes allow reducing the energy consumption of the machine. It is possible to select one or both modes.

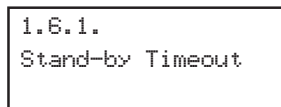

STAND-BY TIMEOUT
The "Stand-by" mode is activated after some minutes of inactivity which can be

set by means of this menu option. By setting it to zero the function is disabled.

When the stand-by mode is activated the boilers are turned off and the display shows the message "Stand-by".

To exit the stand-by mode, press any button or insert some credit. When normal operation is restored, the boilers are turned on and the vending machine starts the warm-up phase.

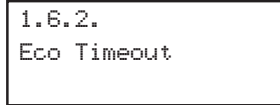

ECO TIMEOUT
The "ECO" mode is activated after some minutes of inactivity which can be set by means of this menu option. By setting it to zero the function is disabled.

When the "ECO" mode is activated, the target temperature of boiler 2 (steam boiler for the "Cappuccino" version and auxiliary boiler for the "Instant" version) is reduced by a preset value (see the following menu option).

The vending machine remains in its "Ready" status and no message is shown to the user.

To exit the ECO mode, press any button or insert some credit. When ECO mode is deactivated, the target temperature for boiler 2 is restored and the machine starts the warm-up phase.

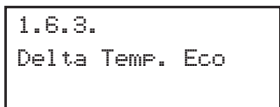

DELTA TEMP. ECO
It allows setting the °C reduction to be applied to the temperature of boiler 2 in "ECO" mode.

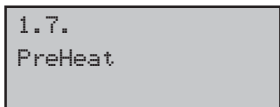

Preheating
This menu allows setting the parameters related to the preheating operations for the brew group, the brewing circuits for instant products or the steam dispensing circuit.

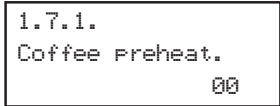

COFFEE PRE-HEATING
It allows enabling a pre-heating cycle of the Brew Group if it remains inactive for a period of time.

This menu allows setting the seconds of inactivity after which the pre-heating cycle has to take place. The settable values are:

- 0 (zero) pre-heating cycle disabled,
- from 60 seconds to 900 seconds at intervals of 60.

The default value is 300.

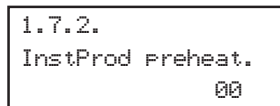

PREHEAT. SOLUBLES
Enables selection of the instant products for which the preheating function will be enabled.

By enabling this function, the vending machine performs a preliminary dispensing of water through the circuit corresponding to the instant product selected. The user can choose for which instant product prerinsing can be enabled, by setting cu cm of water to be used.

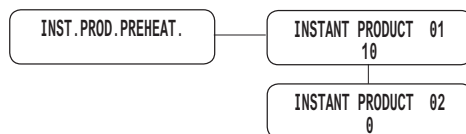

Example: the settings shown in the figure enable preheating for instant product 1 with 10 units of water and do not enable preheating for instant product 2.

Instant product preheating takes place if:

- at least 3 minutes have passed since the mixing bowl was last used;
- the quantity of water for the instant product is < 50 units.

```
1.7.3.
Capp. PreHeat
      00
```

CAPP. PREHEAT

It refers to the circuit of the Cappuccinatore: it allows setting the minutes of inactivity

after which a preheating cycle is requested before dispensing steam (by setting this value to zero the preheating cycle is disabled). This cycle improves the operation of the Cappuccinatore after a long period of inactivity.

```
1.7.3.1.
Warm-Up T-Out
      00
```

WARM-UP T-OUT

It determines the delay time (in minutes) after which the preheating of the

Cappuccinatore is enabled.

```
1.7.3.2.
Extra Time
      00
```

EXTRA TIME

Extra time (in tenths of seconds) for steam dispensing applied in case the circuit is cold, since a

reduced quantity of milk is dispensed in this case.

```
1.8.
Steam Cleaning
```

Steam Cleaning

In case the steam circuit remains inactive for some hours (to be set under the option "Steam

Cleaning Time") the vending machine will not allow brewing any beverages with steam (under the letter "S" in the product list) unless a cleaning cycle is activated. The message "NO Cappuccino" will be displayed (by setting the number of hours to zero the cleaning message and the stop status will be disabled). The cycle can be activated in the "Maintenance" menu as well as during normal operation of the machine through the user cycle.

ACTIVATION USING THE MENU:

Select the option 1.8 in the "Maintenance" menu.

ACTIVATION DURING NORMAL OPERATION:

The machine must comply with the following:

1. Vending machine in its "Ready" status.
2. No brewing in progress.
3. Option "Enable Steam Wash" in the "System Management" menu enabled.

To activate the cycle simply press the buttons corresponding to beverages 4 and 8 simultaneously.

CYCLE DESCRIPTION:

The cycle operation is independent from the activation mode (no matter if started or not from the "Maintenance" menu) and it consists of two phases: the "Wash Cycle" and "Rinse Cycle".

1. During the first phase, a display message will request to pour the mix of water and cleaning solution (about 400 gr of water and Saeco compound). Simultaneously press the buttons corresponding to beverages 4 and 8 to start the "Wash Cycle". This phase will last 75 seconds, then

the machine will pass to the following one.

2. During the second phase, a display message will request to insert only the water container (about 400 gr of water). Simultaneously press the buttons corresponding to beverages 4 and 8 to start the "Rinse Cycle". This cycle will last 75 seconds. At the end of this procedure, the cleaning cycle will be considered as completed and the Cappuccinatore as cleaned, thus enabling brewing beverages with milk.

```
1.8.1.
Steam Cleaning Time
```

Steam Cleaning Time

It refers to the circuit of the Cappuccinatore: it allows setting the interval (in hours)

after which a cleaning cycle of the circuit is requested.

```
1.8.2.
Enable Steam Wash
```

Enable Steam Wash

If set on YES, it allows starting the cleaning cycle by simultaneously pressing the

two beverage buttons 4 and 8.

This allows executing a cleaning cycle on the circuit of the Cappuccinatore without the need to open the machine.

```
1.9.
Rinse cycle
      Si
```

Rinsing Cycle

It allows enabling of the automatic rinsing of the mixing bowls. The automatic rinsing is

performed as follows: the first rinsing takes place 10 minutes after the "machine ready" status; if necessary, other rinses occur 7 hours after the last dispensing.

```
1.10.
Pre-grinding
      Si
```

Pre-grinding

Enables instant pre-grinding of the coffee dose.

```
1.11.
Program messages
      ...
```

Programmable texts

```
1.11.1.
Stand-by
** DASP MY07 **
```

STAND-BY TEXT

It enables setting the message appearing on the display when the vending machine is in standard operating mode.

```
1.11.2.
Preselection
Bevande con orzo
```

PRESELECTION TEXT

It allows setting the message appearing on the display when the preselection mode of the

preselection key is active.

```
1.11.3.
Brewing
Attendere
```

DISPENSING TEXT

It allows setting the message appearing on the display when the vending machine is dispensing a product.

```
1.11.4.
  Out of service
  Chiama assist.
```

OUT OF SERVICE TEXT
It enables setting the text on the display when the vending machine stops due to a fault.

```
1.12.
  Contrast
```

Contrast
Adjusts the contrast of the display.

```
1.13.
  Pulse counter
  Coffee
```

Coffee / beverage pulse counter

Enables selection of whether the 24V dc electromechanical

pulse counter (optional - to be connected to the CPU card) has to count the coffees or all dispensed beverages.

```
1.14.
  Clock
```

Clock

Enables setting of the hour, minute, day of the week, day of the month, month and year.

```
1.14.1.
  Time
  08:00
```

```
1.14.2.
  Date
  01 Gen 08
```

```
1.15.
  Multiple bever.
  ...
```

Multiple beverage

Enables selection of the beverages to be enabled for multiple dispensing and the maximum number of beverages dispensed. The upper line will remain the same for all following operations, while the

lower line will display the number of consecutive beverages. It is possible to set a value between 2 and 8.

```
1.15.2.
  Enable MultBev
```

BEVERAGES ENABLING
It allows enabling or disabling of the beverage keys.

```
1.15.2.
  Beverage      1
  Yes
```

During standard operation the message "NOT AVAILABLE" will be displayed when a disabled key is pressed.

```
1.16.
  Enable reset
  No
```

Reset enabling
It allows enabling of the "RESET" for data in the statistics maintenance menu.

```
1.17.
  Free Prod button
  No
```

Free vend key
It enables the "P3" key (Fig. 26) of the CPU card for free dispensing of a product during standard operation.

```
1.18.
  Presel. button
  Beverage
```

Preselection key
The functions associated with the preselection key can be selected from the following:

- **PRESELECTION:** by pressing this key the vending machine displays the preselection message ("PRESELECTION by default) and makes another group of beverages available.



Important

With this configuration it is necessary to set the new beverage/recipe group available (see the BEVERAGE BREWING menu).

- Beverage: in this case, pressing the button will dispense beverage / recipe number 5.
- DISABLED pressing the key has no effect.

```
1.19.
  Language
```

Language

Enables selection of the language to be used by the vending machine. Languages

available: Italian, English, French, German, Spanish, Portuguese and Dutch.

```
1.20.
  Change password
```

Password change

Enables setting of a password or modification of the current one.

The password consists of a number between 000001 and 999999. The 000000 value (default value) means no password. To set the password, press UP and DOWN keys and confirm with the ENTER key.

```
1.20.1.
  Prog. password
```

PROG.PASSWORD

Allows a password to be set for the programming menu.

```
1.20.2.
  Service password
```

SERVICE PASSWORD

Allows a password to be set for the maintenance menu.

```
1.21.
  On/Off time
  ...
```

On/Off Time

Allows you to set the vending machine's automatic on and off time ranges over the course of a week.

```
1.21.1.
  On 1
  Immevsd  00:00
```

```
1.21.2.
  Off 1
  Immevsd  00:00
```

```
1.21.3.
  On 2
  Immevsd  00:00
```

```
1.21.4.
  Off 2
  Immevsd  00:00
```

1.22.
EVA-DTS

EVA-DTS

Allows selecting the category of data that will be transferred by the VM during an Audit Eva Dts session.

1.22.1.
EA1..2 (Events)

1.22.2.
EA3..5 (Readout)

1.22.3.
LA1-Prices Lists

1.22.3.1.
LA1 Normal Prices

1.22.3.2.
LA1 Diff1 Prices

1.22.3.3.
LA1 Diff2 Prices

1.22.3.4.
LA1 Card Prices

1.22.3.5.
LA1 Free

1.22.3.6.
LA1 Test

1.22.4.
PA1..4 -Products

1.22.5.
VA1..3 Sales

1.22.6.
BA1-CA15-Cash

1.22.7.
DA1..7-CashLess

1.23.
Audit Mss. Enable

Audit Msg. Enable

It allows displaying for a few seconds the selection counters (total and since last reset) during the machine start-up phase.

1.24.
Ev Water Assign.

EV Water Assign

By setting the "W" value in the product list, hot water will be dispensed. This menu allows choosing the solenoid valve to be used for dispensing. If the "hot water solenoid valve" kit is installed, set the value to 0 (zero) or select the solenoid valve operating on the desired circuit among the available ones.

1.25.
Complete Menus

Complete menu

Enables selection of whether the entries of the programming menu should be shown fully or only partially.

1.26.
VM Model

VM Model

It allows selecting the current model of the vending machine.

The possible options are:

Espresso

Cappuccino

TTT

Instant

The vending machine model is specified on the label located in the inside of the right-hand side panel (Fig.37).

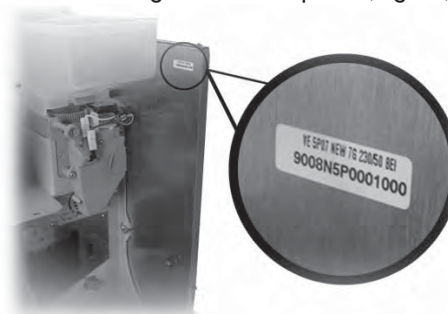

Fig. 37

1.27.
Factory Default

Factory default

It allows reverting the programmable parameters to factory preset values.

1.28.
System Info

System Info

This option allows accessing a page showing the overall machine configuration.

The display shows the following information:

FIRST ROW: Sw version ("x.yy.zz" format) / Program CRC ("abcd" format)

Example: "SW v1.02.12/087c"

SECOND ROW: Boot loader version ("xx" format) and name of the file searched for by the boot loader on the USB key (".s19" extension not displayed)

Example: "Boot 08SAE_DA5P"

THIRD ROW: Memory version ("xxx.yyy." format) / Content CRC ("zzz" format)

Example: "Mem 123.456.789"

PAYMENT SYSTEMS

```
2.
Payment system
...
```

The entries of the PAYMENT SYSTEMS are:

```
2.1.
Protocol
...
```

Protocol

Enables selection of the protocol used by the vending machine to dialogue with the payment system installed on it:

- EXECUTIVE protocol;
- PRICE HOLDING/DISP Protocol;
- BDV Protocol;
- MBD Protocol;
- NO PROTOCOL (no serial protocol);
- Master/Slave executive (the vending machine operates as master for another vending machine);
- PHD Master /Slave (the vending machine operates as master for another vending machine that works with the PRICE HOLDING/DISP protocol);
- MDB SLAVE (the vending machine operates as slave to another machine);

The "NO PROTOCOL" setting will be used when a payment system operating with one of the protocols provided by the other settings "EXECUTIVE", "PRICE HOLDING", "BDV", "MDB" "MDB SLAVE" or "EXEC MASTER/SLAVE" is not installed on the VM.

This setting is necessary since the VM continuously checks for dialogue with the provided payment system. If the VM detects no dialogue, it signals this fault on the display through the message "NO LINK".

This signal cannot be considered an error condition.

```
2.2.
Parallel coiner
...
```

Parallel coiner

Allows enabling of the parameters of the parallel coiner, the mechanical coiner, the cancelling machine and the choice of values to be assigned to the single money channels.

the cancelling machine and the choice of values to be assigned to the single money channels.

Entry description:

```
2.2.1.
Enable
No
```

ENABLE: By setting "Y", the parallel coiner, the mechanical coiner and the cancelling machine control are enabled.

By setting "N", a parallel coiner which may be connected to the vending machine is always disabled.

```
2.2.2.
Coin values
...
```

```
2.2.2.1.
Moneta    1/6
          0.00
```

COIN VALUE: Enables setting of the value of the coins transferred to the vending machine from the parallel coiner, the mechanical coiner and the cancelling machine.

The following table shows the channel/payment system combinations.

Channel	Payment system
1	Parallel coiner
2	Parallel coiner
3	Parallel coiner
4	Parallel coiner
5	Parallel coiner
6	Parallel coiner
7	Cancelling machine

```
2.3.
Banknote reader
...
```

Banknote Reader

It enables the parameters of the parallel banknote validator and the choice of values to be assigned to single banknote channels.

Entry description:

```
2.3.1.
Enable
No
```

ENABLE: By setting "Y", the management of the parallel reader is enabled. By setting "N", a parallel reader which

may be connected to the vending machine is always disabled.

```
2.3.2.
Inhibition level
255
```

INHIBITION LEVEL: Enables setting of the active level of the banknote reader inhibition signal.

```
2.3.3.
Banknote values
...
```

BANKNOTE VALUE: Enables setting of the value of banknotes transferred to the vending machine from the parallel reader.

```
2.3.3.1.
Banconota  1/4
           0.00
```

```
2.4.
MDB settings
...
```

MDB settings

Enables access to particular functions of the MDB protocol.

```
2.4.1
Recharge enabled
No
```

RECHARGE: Allows disabling or enabling of any Saeco card recharge operation.

By setting RECHARGE = NO the vending machine will only deduct the cost from MDB cards.

```
2.4.2.
Max CardRecharge
10.00
```

MAX CARD RECHARGE: Enables setting of the maximum credit level, beyond which all recharge operations (if enabled) are ineffective.

By setting MAX RECHARGE = 20.00, the credit on the vending machine will be transferred to the card if the sum does not exceed 20.00.

```
2.4.3.
Max card charge
10.00
```

MAX CARD VALUE: Enables setting of the maximum credit level, beyond which the card is rejected by the system.

By setting Max card value = 25.00, the vending machine will reject all cards with a credit which exceeds this amount. If this card is detected, the display will not show the credit but a "—" message will be displayed and no sale will be carried out.

```
2.4.4.
Coins enablings
...
```

COINS ENABLING: Enables selection of which coins will be accepted by the change-giving coiner. By setting "Y" a specific coin will be accepted.

```
2.4.4.1.
Moneta 1/16
No
```

On the contrary, the "N" setting prevents the change-giving coiner from accepting

a particular coin. Coins beneath the vending machine scale factor are always disabled and display the "N" setting.

```
2.4.5.
Alt. payout
No
```

ALT. PAYOUT: It enables/disables use of Alternative Payout for the level 3 MDB change-giver. By setting "Yes"

the change-giver is called on to dispense change. Change is limited to 255 times the scaling factor (typically Euro12.75 for the Euro area - with scaling factor of 5). By setting "No" change is given by exploiting the machine's algorithm. Max. change is 60000 units (typically Euro 600 for the Euro area).

```
2.4.6.
Max change
0.00
```

MAX CHANGE: Enables setting of the maximum amount of change which can be dispensed by the change-giving coiner. Default = 10.00.

```
2.4.7.
Exact change
0
```

EXACT CHANGE POLICY: In MDB change-giving coiners, the condition of no change available can be selected within the following table:

Key:

L = channel with the lowest coin value below the minimum level

M = channel with the medium-low coin value below the minimum level

HL = channel with the medium-high coin value below the minimum level

HH = channel with the highest coin value below the minimum level

No.	Description
0	L or M or HL or HH
1	L or M
2	HL or HH
3	L or HH
4	L
5	M
6	HL
7	L and HH
8	HL and HH
9	L and M
10	L and M and HL and HH
11	L and HL or L and HH
12	L or HL and HH
13	HH
14	L and M and HL
15	Never (change always available)

Note

Even if the no change available message is displayed, the vending machine continues to give change as long as coins are present in the channels. The minimum level (same for all channels) can be set on a special menu item.

```
2.4.8.
Min tube level
0
```

CHANNEL LEVEL LOW: Enables setting of the minimum number of coins in the channels. Default = 4.

```
2.4.9.
Tube filling
...
```

MANUAL CHANNEL LOAD: Allows the change-giving coiner channels to be filled manually. Press Esc to exit the channel loading mode.

```
2.4.10.
Tube emptying
...
```

MANUAL CHANNEL EMPT.: Allows the change-giving coiner channels to be emptied by pressing the beverage selection keys.

```
2.4.11
Commit to vend
      No
```

COMMITTED TO VEND: By setting "N", the credit inserted can be returned even if no sale has been made. This function may be useful, for example, for changing banknotes into coins. By setting "Y", the credit inserted can be returned as change only after the sale has been completed. Default = YES.

```
2.4.12
Banknote enabl.
      ...
```

BANKNOTES ENABLING: Enables selection of which banknotes will be accepted by the MDB banknote reader.

```
2.4.12.1
Banknote      1/16
      No
```

A specific banknote is enabled for acceptance by setting "Y". On the contrary, the "N" setting prevents the banknote reader from accepting a specific banknote. Default = All enabled.

```
2.4.13.
Banknote escrow
      No
```

BANKNOTE ESCROW: By setting "Y", an inserted banknote is stored in the escrow position by the banknote reader (if supported); this function is supported by the banknote reader. In this way, if the sale fails or the card system fails to charge, the banknote will be returned. By setting "N", any inserted banknote goes to the banknote reader's stacker, so that the banknotes cannot be returned. Default = No.

```
2.4.14.
Slave address
      0x40
```

SLAVE ADDRESS: When the vending machine is in Master mode, this menu enables setting of the address of any slave connected vending machine. If the vending machine is in Slave mode, it enables setting of its address. Possible addresses are 0x40, 0x48 and 0x50. Default = 0x40.

```
2.5.
Max credit
      2.55
```

Max credit
This allows the user to set the maximum credit which can be accepted by the vending machine. Once this limit has been reached, the payment systems are disabled so that no more credit can be accepted. Default = 20.00.

```
2.6.
Multivend
      No
```

Multivend
Enables the user to use any residual credit to purchase other beverages. By setting "N" (no), the residual credit will be collected by the vending machine.

```
2.7.
Overpay time
      180
```

Overpay Time
It establishes the maximum time (expressed in seconds) beyond which the vending machine collects the displayed residual credit. The time is adjustable at intervals of 10 seconds. By setting "000" the function is disabled.

```
2.8.
Fixed zeros
      0
```

Fixed Zeros
Allows setting of the number of fixed zeros for credit.

```
2.9.
Decimal disits
      0
```

Decimal point posit.
Enables setting of the position of the decimal point of the credit.

3.
Product setup

IMPOSTAZIONE PRODOTTI

3.1.
Prod. before

Product before

It allows selecting the instant product for which you wish to enable powder dispensing before water dispensing. This brewing cycle will be carried out only when the quantity of powder to be brewed does not exceed 34.

3.1.1.
Instant Product1/5
No

3.2.
Beverage enabled

Beverage validation

It allows to enable or disable the beverage keys.

By pressing a disabled key during operation, the message "NOT AVAILABLE" will be displayed.

3.2.
Beverage 1
Yes

The combination BUTTON - BEVERAGE NUMBER changes if button "5" is used as the "PRESELECTION" button.

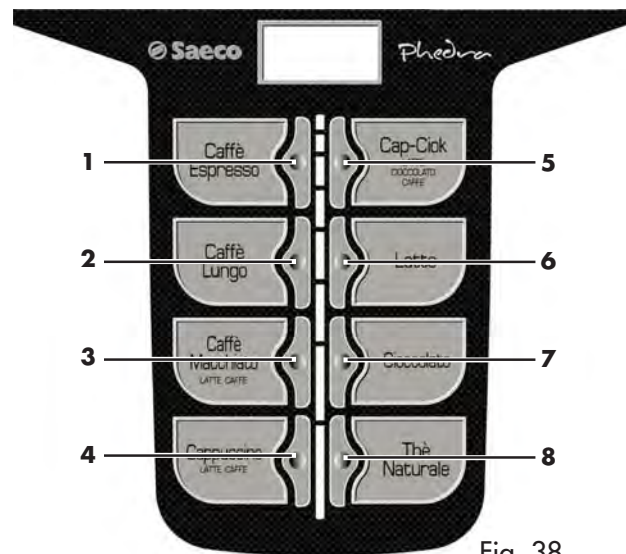

Fig. 38

KEY 5 = BEVERAGE 5

KEY	Press KEY
1	Beverage 1
2	Beverage 2
3	Beverage 3
4	Beverage 4
5	Beverage 5
6	Beverage 6
7	Beverage 7
8	Beverage 8

KEY 5 = PRESELECTION

KEY	Press KEY	Press PRESELECTION+KEY
1	Beverage 1	Beverage 9
2	Beverage 2	Beverage 10
3	Beverage 3	Beverage 11
4	Beverage 4	Beverage 12
5	Preselection	Preselection
6	Beverage 6	Beverage 14
7	Beverage 7	Beverage 15
8	Beverage 8	Beverage 16

3.3.
Beverage brewing

BEVERAGE BREWING

The vending machine is able to dispense 14 beverages. Each beverage can be prepared using coffee beans and/or instant products. The technician can select the desired products for the recipe (max 4) and order of use. Each component is identified by a number or a digit (Fig. 39).

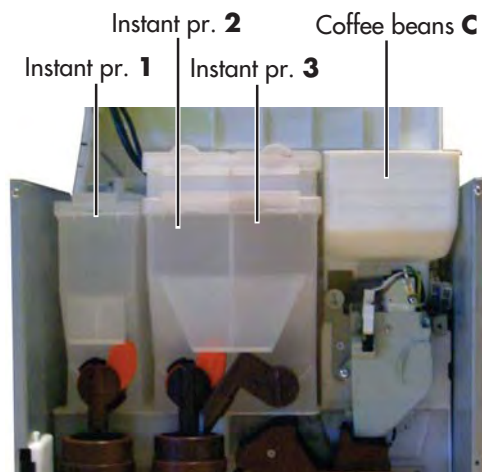

Fig. 39

```
3.3.
Beverage      1
              ...
```

```
3.3.
Beverage      1
Sequence     0000
```

SEQUENCE

This is the order in which the products making up the beverage are brewed. The possible choices are:

0 = does not dispense any product
1 = dispenses product 1
2 = dispenses product 2

3 = dispenses product 3

4 = dispenses product 4

5 = dispenses product 5

C = brews coffee using instantly ground coffee

F = brews "fresh brew" coffee using pre-ground coffee

P = brews espresso coffee using pre-ground coffee

B = brews "fresh brew" coffee using instantly ground coffee

W = dispenses hot water

S = dispenses steam in the Cappuccinatore

Consequently, the combination of "3C00" or "30C0" or "03C0" will always dispense product 3 and coffee beans.

The settings of products making up the beverage will be requested according to the sequence.

```
3.3.
Beverage      1
H2O coffee    38
```

COFFEE WATER, PRE-GROUND WATER, FRESH-BREW WATER, BEANS WATER

It allows setting the quantity of water to be dispensed for the programmed coffee type (C, P, F, or B). The quantity can be set from "1" to "999".

```
3.3.
Beverage      1
Steam Duration
```

STEAM DURATION

It determines the activation time (in tenths of seconds) for dispensing steam through the

Cappuccinatore.

```
3.3.
Beverage      1
Just water    101
```

JUST WATER

Defines the amount of hot water to be dispensed.

The amount of coffee that can be brewed can be adjusted from "1" to "999".

```
3.3.
Beverage      1
% InstProd 3: 50
```

% INSTANT PRODUCT

It determines the instant powder delivery rate.

The value can be set between 10 and 100. The lower the value the smaller the powder delivery rate.

```
3.3.
Beverage      1
% Pump 3: 50
```

% PUMP

It determines the water delivery rate.

The value can be set between 20 and 100. The lower the value the smaller the water delivery rate.

**Important**

If the sequence includes several instant products, the sequence "INSTANT PRODUCT - WATER - DELAY - INSTANT PRODUCTS - % OF INSTANT PRODUCT" will be shown again.

If the setting relative to the instant product ("INSTANT PRODUCT - WATER - % INSTANT PRODUCT" - % PUMP) means that the powder dispensing lasts longer than the water dispensing, the vending machine stops powder dosing (to avoid insufficient rinsing of the mixer) and emits a beep. Check the settings again to obtain correct dispensing (powder dispensing must end a few instants before the water dispensing is complete, to allow good rinsing of the mixer).

```
3.3.
Beverage      1
InstProd D.3: 005
```

INSTANT PRODUCT DOSE

This defines the quantity of instant product to be brewed.

Example: "005" quantity

indicates that the motor of the instant product 3 will be activated for 5 tenths of a second.

The quantity of instant product is adjustable from "1" to "500" in steps of 1. Brewing of the instant product does not occur when the parameter is set at "0000" (in this case water is brewed).

```
3.3.
Beverage      1
H2O InstPr.3: 022
```

H2O / INSTANT PRODUCT

It defines the amount of water to be mixed with the instant powder.

Example: "3" indicates that water will be mixed with the instant product 3. "022" indicates that 22 water units will be brewed with the instant product. The reference unit is preset by the manufacturer. The amount of water can be adjusted from "1" to "1500" in steps of 1.

```
3.3.
Beverage      1
Test beverage
```

BEVERAGE TEST

Enables brewing tests to be carried out on the beverage just set.

By pressing ENTER the message "PRESS KEY" is displayed and it is possible to choose the key to be pressed, relative to the type of brewing test:

- 3 key = Full beverage;
- 7 key = Water only;
- 8 key = Powder only.

```
4.
Sales management
...
```

SALES MANAGEMENT

The SALES MANAGEMENT items are:

```
4.1.
Price table
...
```

Price table

99 price levels can be set.

```
4.1.1.
Price          1
              0.00
```

```
4.2.
Beverage prices
...
```

Beverage price

Enables association of one of the price levels set in the PRICE TABLE to each beverage.

The association can be:

```
4.2.1.
Normal
...
```

```
4.2.1.1
Global price
```

GLOBAL PRICE

(all beverages are given the same price level);

```
4.2.1.1
Global price
P00          0.00
```

GLOBAL PRICE SETTING

By pressing the UP and DOWN keys and confirming with ENTER, it is possible to choose

the price level to associate to all beverages.

```
4.2.1.2
Single price
```

SINGLE PRICES

(each beverage will be given a specific price level).

```
4.2.1.2
Single price
B01: P00    0.00
```

SINGLE PRICE SETTING

Enables selection of the price level to associate to each beverage.

Select the beverage to associate to a price using the UP and DOWN keys and confirm with ENTER, then select the price level (from 001 to 099) again with the UP and DOWN keys and confirm with ENTER.

```
4.2.2.
Diff 1
...
```

DIFF. 1

```
4.2.2.1
Global price
```

GLOBAL PRICE

(all beverages are given the same price level);

```
4.2.2.1
Global price
P00          0.00
```

GLOBAL PRICE SETTING

By pressing the UP and DOWN keys and confirming with ENTER, it is possible to choose

the price level to associate to all beverages.

```
4.2.2.2
Single price
```

SINGLE PRICES

(each beverage will be given a specific price level).

```
4.2.2.2
Single price
B01: P00    0.00
```

SINGLE PRICE SETTING

Enables selection of the price level to associate to each beverage.

Select the beverage to associate to a price using the UP and DOWN keys and confirm with ENTER, then select the price level (from 001 to 099) again with the UP and DOWN keys and confirm with ENTER.

```
4.2.3.
Diff 2
...
```

DIFF. 2

```
4.2.3.1
Global price
```

GLOBAL PRICE

(all beverages are given the same price level);

```
4.2.3.1
Global price
P00          0.00
```

GLOBAL PRICE SETTING

By pressing the UP and DOWN keys and confirming with ENTER, it is possible to choose

the price level to associate to all beverages.

```
4.2.3.2
Single price
```

SINGLE PRICES

(each beverage will be given a specific price level).

```
4.2.3.2
Single price
B01: P00    0.00
```

SINGLE PRICE SETTING

Enables selection of the price level to associate to each beverage.

Select the beverage to associate to a price using the UP and DOWN keys and confirm with ENTER, then select the price level (from 001 to 099) again with the UP and DOWN keys and confirm with ENTER.

```
4.2.4.
Card
...
```

CARD

This function enables the application of differentiated prices if the card is used for payment.

```
4.2.4.1
Card prices
No
```

By setting CARD PRICES = YES a new menu entry will appear in PRICE MANAGEMENT, enabling

setting the price level to be applied to the product (beverage or snack) if payment is made by card.

```
4.2.4.2
Global Price
```

GLOBAL PRICE
(all beverages are given the same price level);

```
4.2.4.2
Global Price
P00      0.00
```

GLOBAL PRICE SETTING
By pressing the UP and DOWN keys and confirming with ENTER, it is possible to choose

the price level to associate to all beverages.

```
4.2.4.3
Single Price
```

SINGLE PRICES
(each beverage will be given a specific price level).

```
4.2.4.3
Single Price
B01: P00  0.00
```

SINGLE PRICE SETTING
Enables selection of the price level to associate to each beverage.

Select the beverage to associate to a price using the UP and DOWN keys and confirm with ENTER, then select the price level (from 001 to 099) again with the UP and DOWN keys and confirm with ENTER.

```
4.3.
Free
Mai
```

Free
Allows you to select if the beverages will be provided free-of-charge, upon payment, or free-of-charge within a time range.

```
4.4.
Free on
Immsvsd  00:00
```

Free On/Off
Allows the beginning and end of the free-of-charge beverage supply to be set.

```
4.5.
Free off
Immsvsd  00:00
```

```
4.6.
Diff Prices 1-On
Immsvsd  00:00
```

Diff Prices 1-On/Off
Allows the beginning and end of beverage supply with differentiated prices to be set.

```
4.7.
DiffPrices 1-Off
Immsvsd  00:00
```

```
4.8.
Diff Prices 2-On
Immsvsd  00:00
```

Diff Prices 2-On/Off
Allows the beginning and end of beverage supply with differentiated prices to be set.

```
4.9.
DiffPrices 2-Off
Immsvsd  00:00
```

8.3 Maintenance menu

The structure of the maintenance menu is shown at 8.3.2. All entries present in the maintenance menu are described at 8.3.3.

8.3.1 Entering the maintenance menu



Open the door, exclude the safety device (see paragraph 3.4), and press the button **P2** (Fig. 26) to access the maintenance menu.

To exit the maintenance menu and return to the standard operation of the vending machine:

- Press the ESC button repeatedly until "EXIT ?" appears. Select YES and press ENTER.
- remove the key from the safety switch in order to turn off the vending machine;
- close the door and wait for the self-configuration process to end.

8.3.2 Structure of the maintenance menu

1.	Maintenance
1.1.	Error log
1.2.	Rinse cycles
1.3.	Water filter
1.3.1.	Last filter change
1.3.2.	Remainings qty
1.3.3.	Filter reset
1.4.	Calibrations
1.4.1.	Cof. dosing unit
1.5.	Cool down boiler
1.6.	Drain boiler
1.7.	Boiler filling
1.8.	Steam Cleaning
2.	Statistics
2.1.	Total sales
2.2.	Overpay
2.3.	Card In
2.4.	Card Out
2.5.	Total coins
2.6.	Total banknotes
2.7.	Counters
2.8.	Free
2.9.	Test
2.10.	VMC code
2.11.	Slave VMC
2.12.	Reset

8.3.3 Description of messages in the maintenance menu

```
1.
Maintenance
...
```

MAINTENANCE

This function enables the display and cancellation of any errors that may be present.

It is also possible to carry out maintenance on the vending machine.

To reset the errors, turn the vending machine off and then back on.

```
1.1.
Error log
...
```

Error log

This describes the current error (check the cause in section 11 - Error messages). If no error

is present, this message is not displayed.

After checking the error cause, press the ENTER key to reset the vending machine (see section 11 for the complete list of errors).

Error recording

VM's EEPROM records the important events that occur in the VMC (for example errors that occurred, warning messages, etc.).

Recording takes place when the error condition is detected and consists of saving the following information:

- 1- error code (or warning code) occurred;
- 2- location of signal source (e.g., which spiral motor, if the error is due to a spiral motor, or which coffee or instant product);
- 3- day, month, hour and minute of error detection (this information is available only if the VM is equipped with a timekeeper).

The recordings are included in a list which may contain up to 50 elements; when this limit is exceeded the information is input again starting from position 1 (previous information will be lost).

Note

All errors or faults are stored, except when blocks occur (coffee, instant product, beverage, water).

Display:

```
1.1
ERROR LOG ii/NN
dd MMM          hh:mm
Exx - aabb
```

Format of warning error description recorded in LOG:

Exx	WHAT ==>	xx code error/warning alarm
aabb	WHERE ==>	if Myy = spiral motor yy
aabb	WHERE ==>	if Syy = yy instant product dispensing
aabb	WHERE ==>	if Lyy = yy instant product rinsing
aabb	WHERE ==>	if C -- = coffee brewing
aabb	WHERE ==>	if aabb = hexadecimal codes
ddmmm	WHEN ==>	day in figures, month in string (3 letters)
hh:mm	WHEN ==>	hour:minutes
ii		error index in LOG
NN		number of errors in LOG

1.2.
Rinse cycles

automatic cycle starts, thus activating each instant product circuit in sequence.

1.3.
Water filter

Rinsing Cycles

Enables rinsing of the instant product brewing circuits.

By pressing the ENTER key the

activating each instant product circuit in sequence.

Water Filter

(Only if Complete Menus are enabled) Allows the use of the water filter to be checked.

1.3.1.
Last filter change

LAST FILTER CHANGE

Date of the last filter reset.

1.3.2.
Remainins qty

REMAINING QTY

Number of litres of water that can still be dispensed before the filter needs to be

regenerated. When this value is less than 1, a Warning (W83) is recorded in the Error LOG.

1.3.3.
Filter reset

FILTER RESET

Select YES to indicate a new filter has been installed. This operation returns "Remaining

Qty" to the same value as "Filter Limit" and the date in the "Last Filter Change" is changed to today's date.

1.4.
Calibrations

Calibrations

1.4.1.
Cof. dosins unit

COF. DOSING UNIT

Allows you to check the coffee dose in the dosing unit.

To perform the check, you

must:

- Remove the brew group
- Position a container under the dosing unit to collect the coffee that will be ground.
- Select YES from the menu.

When you press the ENTER button, a coffee dose will be ground and discharged by the dosing unit.

Check that the weight of the coffee dose is within the limits for the brew group used (between 6 and 9 grams for Group 7 g, or between 7 and 11 grams for Group 9 g).

1.5.
Cool down boiler

Boiler Cooling

Allows quick cooling of the boiler.

By selecting the item "BOILER

COOLING" the VM dispenses water until the temperature detected by the sensor placed on the boiler has fallen below 50°C.

A coloured bar on the display indicates the current temperature of the boiler. When the bar disappears the temperature detected is less than 50° and the cooling down operation is completed; the VMC must be turned off.

1.6.
Drain boiler

Boiler emptying

It enables start-up of the automatic discharge cycle of the boiler.

1.7.
Boiler fillins

Boiler Filling

Allows you to automatically fill the coffee boiler with water.

Repeat the cycle until the boiler is full (until water is dispensed from the coffee nozzle).

1.8.
Steam Cleanins

Steam Cleaning

It allows activating the cleaning cycle of the milk dispensing circuit through the

Cappuccinatore. To carry out this cycle, you need to have the special cleaning solution (see paragraph 10.2.9 for further information).

2.
Statistics
...

STATISTICS

2.1.
Total sales
...

Total sales

The total revenue from the sales of all selections and beverages is displayed.

By pressing "ENTER" it is possible to obtain detailed information of this revenue for:

- beverages (further divided according to price level, if required)
- discounts and increases made

2.2.
Overpay
...

Overpay

The amount of credit collected when the OVERPAY time has elapsed is displayed.

2.3.
Card In
...

Card-In

The amount of credit collected from cards is displayed.

2.4.
Card Out
...

Card-Out

The amount of credit charged on cards is displayed.

2.5.
Total coins
...

Total coins

The total value of the coins inserted is displayed.

2.6.
Total banknotes
...

Total banknotes

The total value of the banknotes inserted is displayed.

By pressing "ENTER" it is possible to display the number of banknotes inserted according to their denomination.

2.7.
Counters
...

Counters

The presence of the Timekeeper in this menu allows the extension of the quantity of information

displayed.

It is possible to display the total and partial number of beverages divided into price bands.

2.8.
Free
...

Free

The total number of free beverages dispensed is displayed.

2.9.
Test
...

Test

The total number of test beverages dispensed is displayed.

2.10.
VMC code
...

VM Code

Assigned by the manufacturer.

2.11.
Slave VMC
...

VMC Slave

The amount of sales made by the Slave is displayed.

2.12.
Reset
...

8.4 Machine Ready/Free Button

Open the door, exclude the safety device (see section 3.4), and press button **P3** (Fig. 26).

If pressed during the initial warm-up, this button allows inducing the "MACHINE READY" status before the boilers reach their set temperature.

If pressed after the "MACHINE READY" status is reached, this button allows dispensing a free product (this function can be enabled from the menu 1.18 "FREE BUTTON").

8.5 Reset

Open the door, exclude the safety device (see section 3.4), and press the button **P4** (Fig. 26) to restart the vending machine management programme.

9 - OPERATION AND USE

Important

This appliance is not intended for use by persons (including children) with reduced physical, sensory or mental capabilities, or lack of experience and knowledge, unless they have been given supervision or instruction concerning use of the appliance by a person responsible for their safety.

9.1 Beverage selection

This vending machine is able to dispense 15 beverages.

The following are the conditions necessary to select a beverage:

- the vending machine has reached the set temperature after the start-up. Otherwise, once a beverage key is pressed, the display shows the message "HEATING";
- the credit available is sufficient or the vending machine has been set in free mode. If this is not the case, the display shows the message "INSERT XXX";
- there is no error condition that prevents the dispensing of beverages.
- the beverage selected is enabled. If this is not the case, the message "NOT AVAILABLE" will be displayed;
- there is no block condition for the beverage selected. If this is not the case, the message "BEVERAGE XXX" alternated with "NOT AVAILABLE" is displayed before the key is pressed. After the key is pressed, the display shows the message "NOT AVAILABLE";

Important

During the brewing of a beverage:

- payment systems are disabled;
- the first line on the display shows the programmable dispensing message (default message is: "WAIT FOR PRODUCT").

Beverage selection

If the vending machine is not set to dispense free beverages, insert the credit required.

Press the key corresponding to the beverage required.

When the beverage is dispensed, the message "REMOVE CUP" is displayed. Take the beverage out of the dispensing outlet.



Warning

To avoid scalding, wait for the end of brewing signal (the message "REMOVE CUP" will appear on the display) before placing your hand in the dispensing outlet.

Do not open the dispensing outlet door while the vending machine is brewing.

In case of failures or product missing during the brewing

phase, a message indicating the cause of this stop will appear on the display.

Messages and special warnings are listed in section 11.

9.2 Cappuccino with cold milk function (only for Cappuccino version)

This model is equipped with a special frothing system, which automatically draws milk from an external container (not supplied), like: bottle or Tetra Pak.

To ensure correct operation, make sure that:

- a. The Cappuccinatore is fully inserted on its support hose
- b. The Cappuccinatore is clean, correctly closed, and that the steel needle is also clean and fully inserted in its seat.
- c. The suction hose has no constrictions or bends that might hinder correct milk suction and flow (see Fig. 69).

The machine has been tested for correct operation with milk temperatures between 4 °C and 15 °C.

Important!

It is recommended to **always** use cold milk and to comply with the health and fresh food storage regulations in force in the country of use of the machine.

10 - CLEANING AND MAINTENANCE



Warning

Unplug the power cord before performing any cleaning and/or maintenance operation.

It is prohibited to perform cleaning or maintenance operations on the internal components of the vending machine with the safety microswitch disabling key inserted.

The Manufacturer declines any liability for any damage or malfunctioning caused by incorrect or poor maintenance.



Important

During the loading operations do not stress any of the live electrical parts and do not clean them with damp cloths.



Warning

Avoid using chlorine-based tablets so as to prevent oxidation phenomena inside the vending machine.

10.1 General notes for correct operation



The vending machine and its non-removable components must be cleaned using non abrasive sponges or damp cloths.

Do not direct water jets on the components and/or on the vending machine.

Check for correct brewing of beverages and adjust the grinding when necessary. To guarantee the correct operation of the vending machine it is recommended to conform to the instructions and times indicated in the MAINTENANCE SCHEDULE (see 10.2.1).

10.2 Cleaning and scheduled maintenance



Warning

All components must be rinsed with warm water only, without using any detergent or solvent that could modify their form and operation.

Removable components cannot be rinsed in the dishwasher.

During the cleaning and maintenance operations do not stress the following electrical components: CPU card; starter port; interconnection port.

Do not clean the above mentioned electrical components using damp cloths and/or degreasing detergents. Remove dust residues with a jet of dried compressed air or using an antistatic cloth.

10.2.1 Maintenance schedule



Daily

Use a damp cloth with detergents suitable for cleaning products in contact with food:

- the display (2 - Fig. 1);
- the beverage dispensing outlet (5 - Fig. 1);
- the keypad (4 - Fig. 1).
- the Cappuccinatore (see paragraph 10.2.9 and 10.2.10).

Weekly

- Clean the drip tray and the coffee grounds drawer (see paragraph 10.2.2 and 10.2.3).
- Clean the coffee bean brew group (see paragraph 10.2.4).
- Clean the mixer and dispenser of the instant products (see 10.2.6).

At each supply

- If needed, clean the coffee bean hopper and instant product container (see paragraph 10.2.7).

Monthly

- Clean the dispensing arm (see 10.2.5).
- Clean the coffee grinder (see 10.2.8).

10.2.2 Cleaning the Drip Tray and the Coffee Grounds Drawer



Remove the drip tray and the coffee grounds drawer and clean them carefully (Fig. 40 and 41).



Fig. 40



Fig. 41

10.2.3 Cleaning the tray and drawer - Version with extension



Take out the tray/drawer assembly (Fig.42).



Fig. 42

Take out, empty and thoroughly clean the coffee grounds drawer (Fig.43).

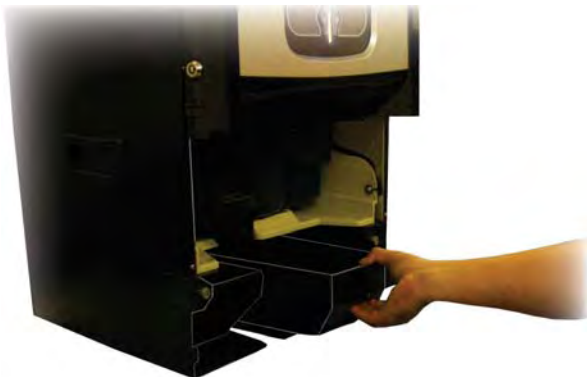

Fig. 43

Take out, empty and thoroughly clean the drip tray (Fig.44).



Fig. 44

Insert the tray/drawer assembly back into place.

10.2.4 Cleaning of the coffee brew group



Disconnect the hose from the dispensing arm (Fig. 45).



Fig. 45

Remove the brew group keeping the lever in 3 position (Fig. 46).



Fig. 46

Wash the brew group with lukewarm water and clean the upper filter carefully (Fig. 47).

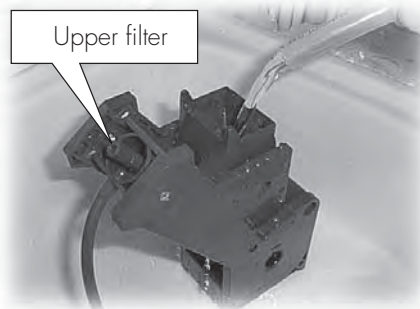

Fig. 47

Important

When inserting the brewing group, make sure that the reference arrows are aligned. If this is not the case, align them using the key provided.

10.2.5 Cleaning the dispensing arm



Remove the elastic which blocks the hoses (Fig. 48).



Fig. 48

push the lock tip (Fig. 49) to release the dispensing arm.



Fig. 49

Wash the components in lukewarm water and assemble in reverse order.

10.2.6 Cleaning the instant product dispenser and the mixer



Disconnect the dispensing tube from the nozzle (Fig. 50).



Fig. 50

Remove the cover and the instant product funnel (Fig. 51).



Fig. 51

Turn the locking ring clockwise (Fig. 48).



Fig. 52

Remove the mixer housing (Fig. 53).



Fig. 53

Carefully use a flat screwdriver as a lever to remove the fan and flange housing cover (Fig. 54).



Fig. 54

Wash all components with lukewarm water and pay particular attention not to damage the fan.

Assemble the components in reverse order and connect the dispensing hose correctly.

10.2.7 Cleaning the containers



To clean the coffee bean hopper the following operations are necessary:

- push the moving panel inward (Fig. 55);
- dispense a few test coffee cups in order to empty the coffee grinder from coffee beans;
- Pull the coffee bean hopper upwards;



Important

After removing the coffee bean hopper, use a vacuum cleaner to thoroughly clean the coffee grinder.

- wash the inside of the container and dry it carefully before reassembling it.



Important

When reassembling the coffee bean hopper, make sure you insert the hook (A) in its place (B) (Fig. 55).

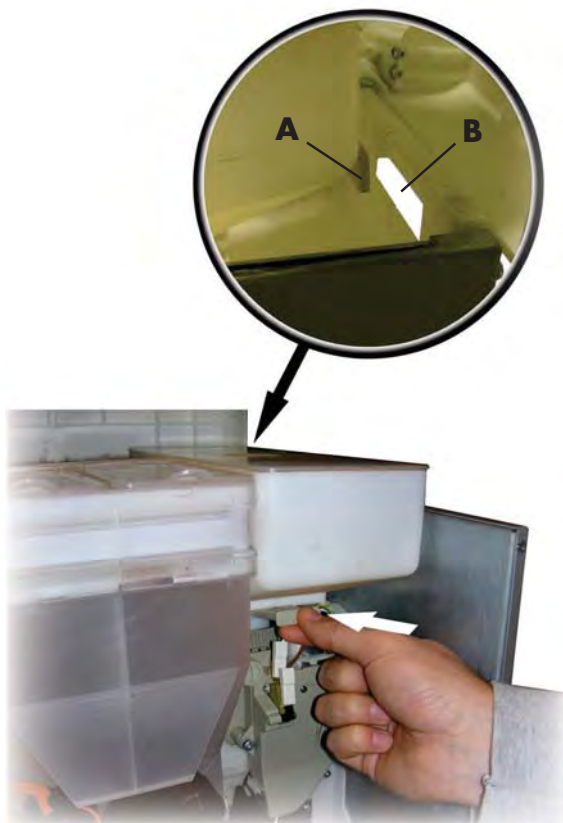

Fig. 55

The following operations are necessary to clean the instant product container:

- Turn the coffee bean hopper locking lever counter-clockwise (Fig. 56).
- Remove the coffee bean hopper by lifting it upwards.
- Wash the inside of the coffee bean hopper and dry it carefully before reassembling it.



Important

When reassembling the coffee bean hopper, make sure you insert the hooks (A) in their place (B) (Fig. 56).

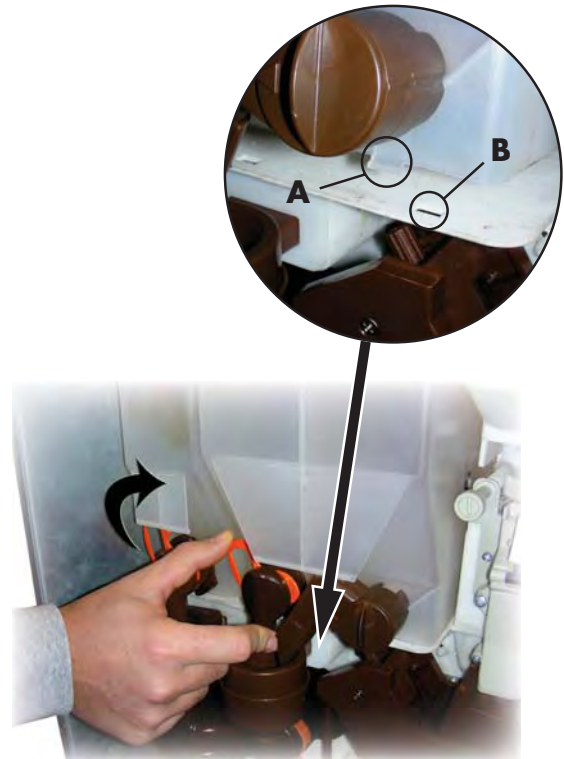

Fig. 56

10.2.8 Cleaning the coffee grinder



Each month, clean the coffee grinder of any residues that might lead to deposits.

After removing the coffee bean hopper (10.2.7 - Fig. 55), clean the coffee grinder carefully with an aspirator.

10.2.9 Semi-automatic cleaning of the Cappuccinatore (only for Cappuccino version)



Take 2 containers having a minimum capacity of 500 cc (Fig.57).

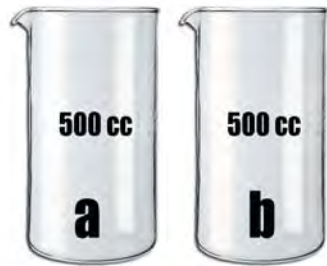

Fig. 57

Prepare the liquid solution "Saeco powder pack for milk circuit" to clean the Cappuccinatore, by mixing the powder with 400 cc of water (Fig.58).



Fig. 58

Slide the milk suction silicone hose out of its container and plunge it in the cleaning solution prepared (Fig.59).

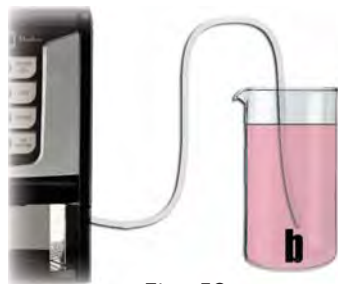

Fig. 59

The procedure can be activated in two ways:

- 1- Access the Maintenance menu and select the "Steam Cleaning" option.
- 2- If the "Enable Steam Wash" option under System Management is set on YES, it is also possible to start the procedure by simultaneously pressing the two buttons at the bottom (4 and 8 - Fig.60).

To carry on the procedure, follow the instructions displayed.



Fig. 60

Place the empty container in the beverage brewing outlet and wait for the time necessary to empty out the cleaning solution. You are now carrying out a cleaning and sanitizing cycle of the Cappuccinatore (Fig.61).



Fig. 61

When all the solution has been dispensed, empty the container and place it back in the outlet (Fig.62).



Fig. 62

Take the hose out of the container previously filled with the solution, thoroughly rinse it and fill with 400 cc of fresh water. Plunge the suction hose again in the container (Fig.63).

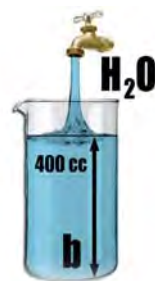

Fig. 63

Simultaneously press the 2 buttons at the bottom (4 and 8). Wait for the time necessary to carry out the final washing (Fig.60).

At the end of the dispensing, empty out the container filled with water (Fig.64).



Fig. 64

The machine is now cleaned and sanitized, ready to operate again.

10.2.10 Manual cleaning of the Cappuccinatore (only for Cappuccino version)



Open the door and slide the Cappuccinatore out of the steam hose (Fig.65).

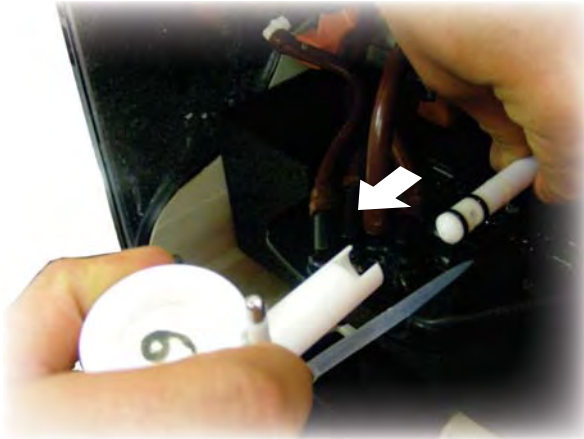

Fig. 65

Separate the Cappuccinatore from the elbow fitting (Fig.66).

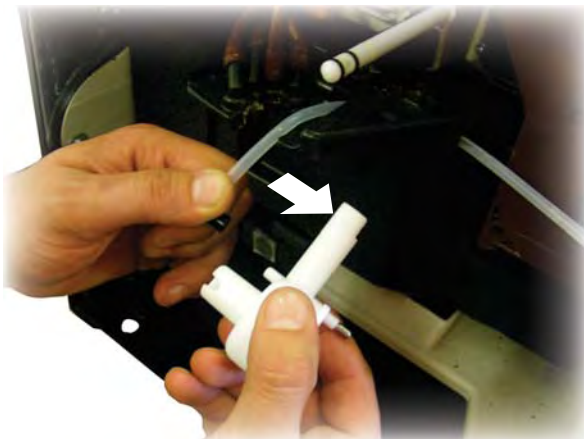

Fig. 66

Remove the cover from the Cappuccinatore (Fig.67).



Fig. 67

Slide out the needle (Fig.68).



Fig. 68

Wash the three disassembled components using water, then reassemble the Cappuccinatore.

Carry out the procedure described above in reverse order to assemble the Cappuccinatore. Make sure the hose is not kinked and that it is correctly routed through its special passages (Fig.69).



Fig. 69

10.3 Software Update



The vending machine management programme is stored in the flash memory included in the "Freescale MC9S12XEP100" microcontroller.

The software update can be performed by using:

- A "VDRIVE2" module (Fig. 70);
- A USB key (Pen Drive);
- A file containing the new software to be loaded.
- In case the connector JP25 is not present on the CPU, it is necessary to use an interface circuit (Fig.72).



Fig. 70

Update procedure:

- Store the "SAE_DA5P.s19" file on a USB key* (file should be stored on the device root);
- Switch off the vending machine;
- Insert the USB key into the VDRIVE2;
- Connect the wiring harness of the VDRIVE2 to the CPU board (connector JP25, Fig.71) or to the interface circuit (Fig. 72);

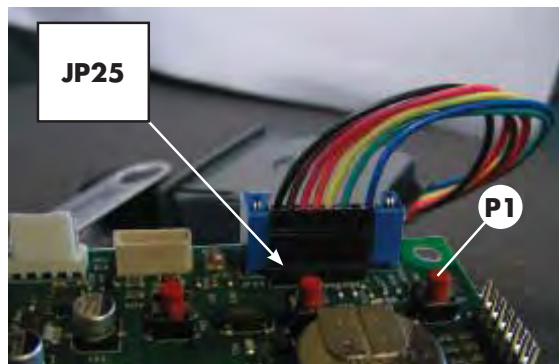

Fig. 71



Fig. 72

- Insert the interface circuit into the blue connector of the CPU board (JP2) (Fig. 73);

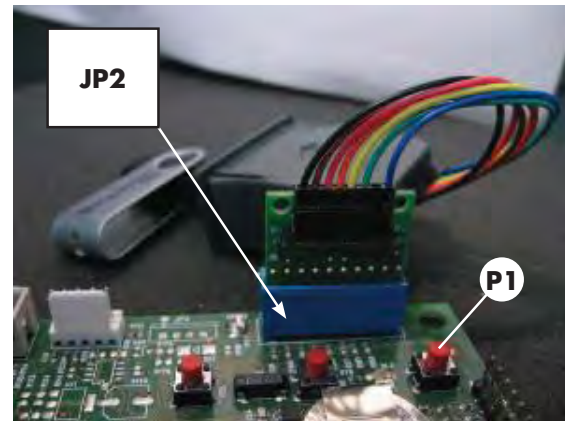

Fig. 73

- Press and hold the **P1** button (Fig. 71 - Fig. 73) on the CPU;
- Switch on the vending machine;
- After a CPU beep** release the **P1** button;
- 3 close beeps and the restart of the vending machine confirm that the software has been updated.
- Switch off the vending machine;
- Remove the VDRIVE and the interface circuit.

- * All common USB keys used on PCs are suitable. Some restrictions are:
- The device has to be FAT12, FAT16 or FAT32 formatted
 - The sector size has to be of 512 Bytes

- **The software update request is notified by the CPU beep. The file search procedure and the following recording on the microcontroller is performed according to the following steps:
- The CPU recognises the USB key and searches for the file with the software to be loaded (green and red lights on the CPU flash alternatively);
 - Once the correct file has been recognised the software is loaded on the CPU;
 - 3 close beeps confirm that the procedure has been completed;
 - In case of errors, a long beep is emitted and the red light stays on.

1 1 - DISPLAY MESSAGES

This section shows the display messages:

- during standard operation;
- in case of a fault (error messages).

1 1.1 Messages during operation

The table below shows a list of messages displayed during the standard operation.

Code	Message	Cause	Remedy
/	PHEDRA	The vending machine is in stand-by.	
/	WAIT FOR PRODUCT	Product dispensing in progress.	
/	REMOVE CUP	Product dispensing finished. Product retire	
/	CAFFEE NOT AVAILABLE	The coffee beans hopper is empty.	Carry out the supply (see section 7).
/	NOT AVAILABLE	A Type of product not available.	
/	NO CHANGE AVAILABLE	The level of coin stacking tubes is below the preset limit.	Add coins into the change-giving coiner.
/	NO LINK	No dialogue with the selected payment system is detected by the VM.	Check for dialogue with the payment system.

1 1.2 Error messages

During operation the vending machine is able to detect a series of faults that may lead to a full or partial blockage of its functions. In case of total blockage, the first line on the display will show the out-of-service message, while the second line will display the fault code; an example is given:



In this case the vending machine is out of service. To bring it back into working order again, it is necessary to remove the cause of the fault and to restart the vending machine.

TABLE

Cause	Code	Registered in ERROR LOG as error or warning	Effect	Automatic reset at restarting	Error resettable from 5-key keypad	Check the "health" status of the VMC using the VMC or refer to the loader (using reset on the 5 key keypad)
No water (from water network or tank)	1	W/E	blocked V. M.	YES	YES	VMC
no coffee dosing unit level detected (coffee not available?)	2	E	coffee blocked	YES	YES	Loader
no movement of group gearmotor detected	3	E	coffee blocked	YES	YES	VMC
no movement of group gearmotor detected	4	E	coffee blocked	YES	YES	VMC
no flowmeter pulses detected	5	E	blocked V. M.	YES	YES	VMC
reading of temperature sensor out of range	13	E	blocked V. M.	YES	YES	VMC
reading of coffee temperature sensor out of range	14	E	blocked V. M.	YES	YES	VMC
e2prom corrupted	16	E	blocked V. M.	YES	YES	VMC
no brew group detected	20	E	coffee blocked	YES	YES	VMC
no dreg drawer detected	21	W	Scheduled maint.	YES	YES	VMC
abnormal flow detected in coffee brewing	22	W/E	Stop coffee (if error)	YES	YES	Loader
pump timeout	23	W	message in log error	–	YES	VMC
no instant product boiler level detected	24	E	blocked V. M.	–	YES	VMC
setting of decimal point position detected not consistent with payment system	31	E	blocked V. M.	YES	YES	VMC
credit management restarting message	32	W	message in log error	–	YES	–
Normal operation restored message after abnormal flow	34	W	message in log error	–	YES	–
MDB slave error detected	35	W	message in log error	–	YES	VMC
coffee boiler heating slow	36	E	blocked V. M.	YES	YES	VMC
instant product boiler heating slow	37	E	blocked V. M.	YES	YES	VMC
CRC flash error	38	E	blocked V. M.	YES	YES	VMC
BDV message	41	E	message in log error	–	–	–
reset vending machine (watchdog intervention)	72	W	message in log error	–	–	–
change-giving coiner error message	80	W	message in log error	–	–	–
filter countdown for water softener resin regeneration has run down	83	W	message in log error	–	–	–
stop funds intervened	84	W	message in log error	–	–	–
boiler filling procedure not completed successfully	85	E	blocked V. M.	YES	YES	VMC
both boilers out of service	86	E	blocked V. M.	YES	YES	VMC
sensor type incorrect (probably a wrong VM model has been selected)	87	E	blocked V. M.	YES	YES	VMC

12 - STORAGE - DISPOSAL

12.1 Change of location



Should the vending machine be positioned in another site it is necessary to carry out the following operations:

- unplug the vending machine;
- Empty the instant product containers and the coffee bean hopper
- Execute the Drain Boiler cycle (maintenance menu)
- Empty the drip tray and the coffee grounds drawer (see paragraph 10.2.2 - 10.2.3).
- clean the vending machine as indicated in section 10;
- put the components back in place and close the doors;
- lift and position the vending machine in the site chosen as indicated at 5.2.

12.2 Inactivity and storage periods

If the vending machine needs to be stored or remains inactive for a long period, it is necessary to carry out the same operations as described at 12.1:

- wrap the vending machine in a tarpaulin to protect it from dust and damp;
- check that the vending machine is in a suitable place (the temperature should not be less than 1°C) taking care not to place any boxes or appliances over it.

13 - INSTRUCTIONS FOR END-OF-LIFE DISPOSAL TREATMENT

This product complies with EU Directive 2002/96/EC.



The symbol  on the product or on its packaging indicates that this product may not be treated as household waste. Instead it shall be handed over to the applicable collection point for the recycling of electrical and electronic equipment.

By ensuring this product is disposed of correctly, you will help prevent potential negative consequences for the environment and human health, which could otherwise be caused by inappropriate waste handling of this product. For more detailed information about recycling of this product, please contact your local city office, your household waste disposal service or the shop where you purchased the product.



Warning

The disposal of the vending machine or of a part of it must be carried out with full respect of the environment and according to local laws in force.