



Vending Machine

D.A. CRISTALLO 400

D.A. CRISTALLO 600



Type: D.A. FS 400
Type: D.A. FS 600



USE AND MAINTENANCE

WARNING: This instruction manual is intended exclusively for specialized personnel.

For more information visit www.Gumball.com | 800-260-0010 | +1-214-550-5079

**MAIN PARTS
CRISTALLO 600**

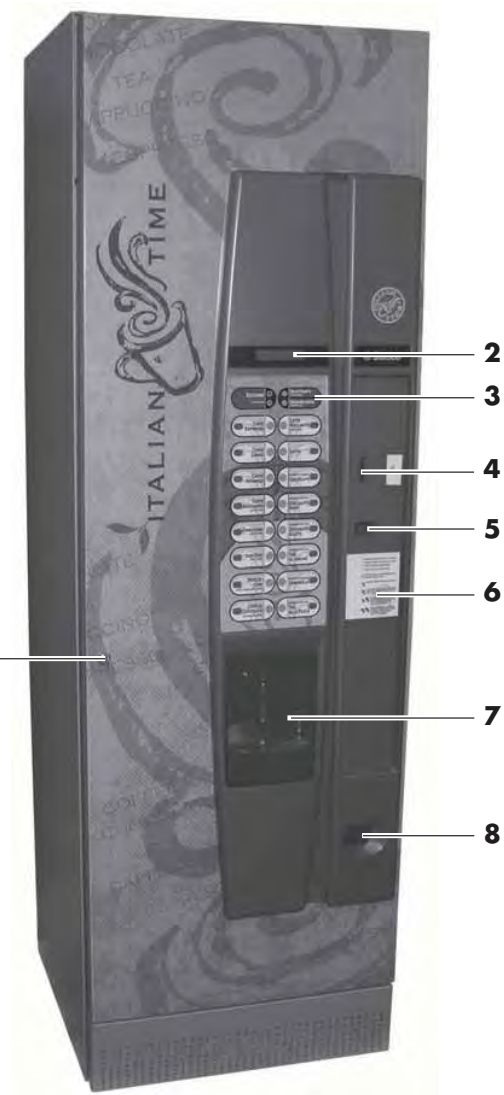

Fig. 1

- | | |
|---|---|
| <ul style="list-style-type: none"> 1 Door lock 2 Display 3 Product keypad 4 Coin slot 5 Change return key 6 Instruction plate 7 Dispensing outlet door (beverage/cup dispensing) 8 Change removal outlet 9 Power cord socket 10 Water connection coupling 11 Safety switch 12 Container 5 (instant products) 13 Container 1/2 (instant products) 14 Container 3/4 (instant products) 15 Coffee bean hopper 16 Coffee grinder 17 Mixer 18 Instants opening | <ul style="list-style-type: none"> 19 Spiral mixer 20 Brew group 21 Drip Tray 22 Dispensing arm 23 Coffee ground channel 24 Fluid discharge tank 25 Collecting tray 26 Door open alarm switch 27 CPU card 28 Cup dispenser 29 Stirrer dispenser 30 Sugar container 31 Change-giving coiner support 32 Dispensing outlet 33 Coin return duct 34 Coin box set 35 Sugar opening 36 Chute |
|---|---|

MAIN PARTS CRISTALLO 600

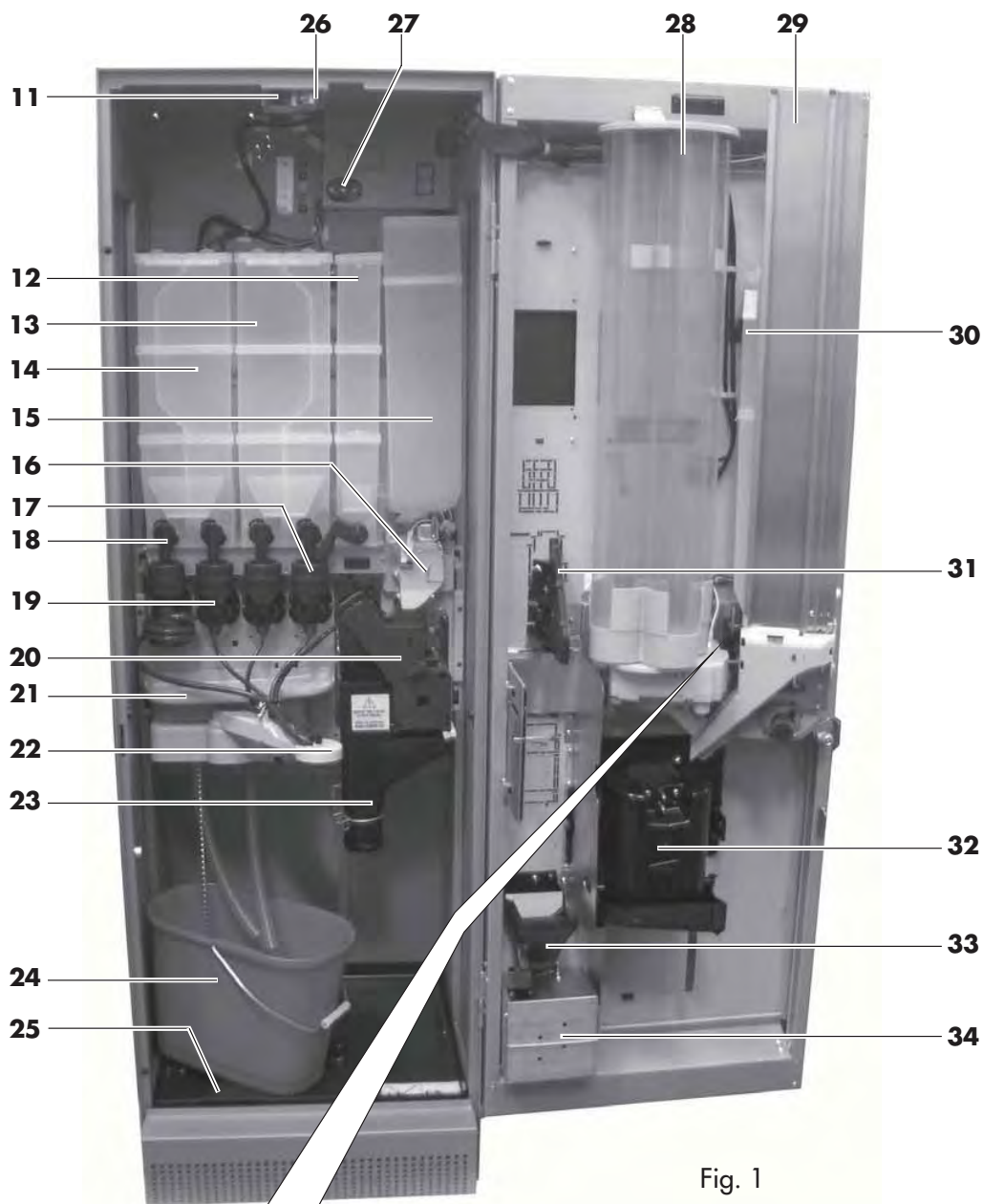
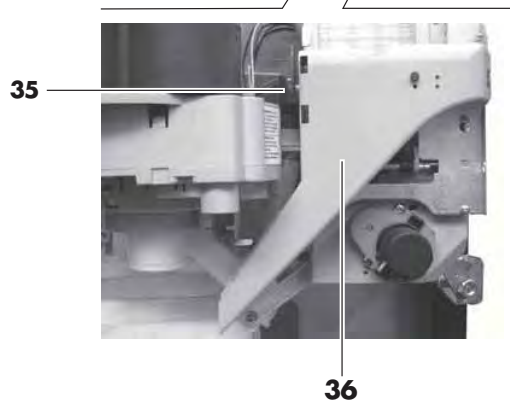

Fig. 1



**MAIN PARTS
CRISTALLO 400**

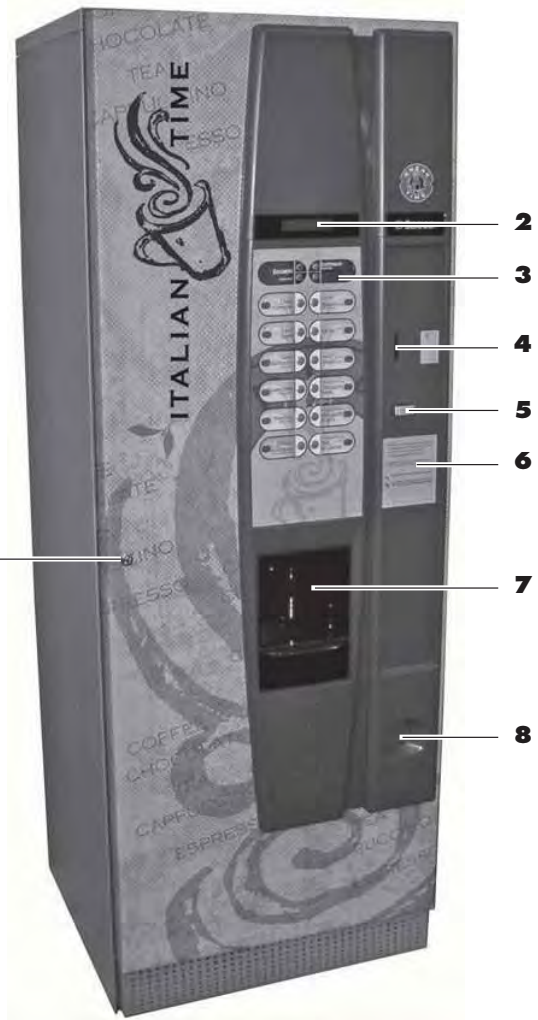

Fig. 1

- 1** Door lock
- 2** Display
- 3** Product keypad
- 4** Coin slot
- 5** Change return key
- 6** Instruction plate
- 7** Dispensing outlet door (beverage/cup dispensing)
- 8** Change removal outlet
- 9** Power cord socket
- 10** Water connection coupling
- 11** Safety switch
- 12** Air break device
- 13** Container 1/2 (instant products)
- 14** Container 3/4 (instant products)
- 15** Coffee bean hopper
- 16** Coffee grinder
- 17** Mixer
- 18** Instants opening

- 19** Spiral mixer
- 20** Brew group
- 21** Drip Tray
- 22** Dispensing arm
- 23** Coffee ground channel
- 24** Fluid discharge tank
- 25** Collecting tray
- 26** Door open alarm switch
- 27** CPU card
- 28** Cup dispenser
- 29** Stirrer dispenser
- 30** Sugar container
- 31** Change-giving coiner support
- 32** Dispensing outlet
- 33** Coin return duct
- 34** Coin box set
- 35** Sugar opening
- 36** Chute

MAIN PARTS CRISTALLO 400

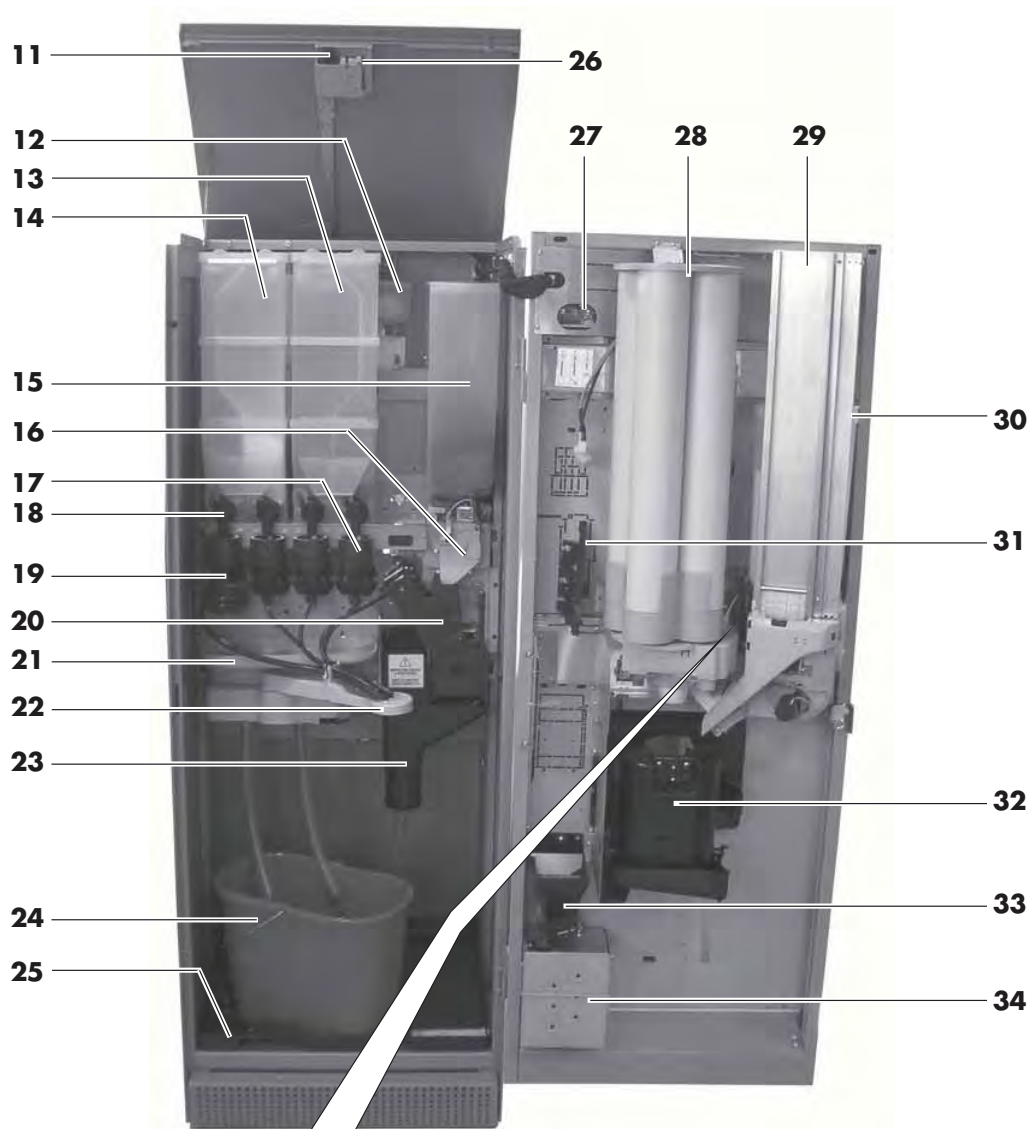
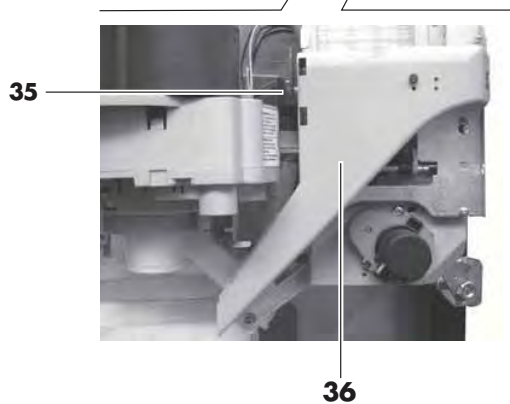

Fig. 1



CONTENTS

MAIN PARTS CRISTALLO 600	2	7	SUPPLY AND STARTING UP	22
MAIN PARTS CRISTALLO 600	3	7.1	Container supply	22
MAIN PARTS CRISTALLO 400	4	7.1.1	Instant product supply	22
MAIN PARTS CRISTALLO 400	5	7.1.2	Sugar supply	23
CONTENTS	6	7.1.3	Coffee bean supply	23
1 INTRODUCTION TO THE MANUAL . 7		7.2	Dose calibration	24
1.1 Introduction	7	7.4	Stirrer supply	24
1.2 Symbols used	7	7.3	Coffee grinding calibration	24
2 INFORMATION ON THE VENDING MACHINE..... 7		7.5	Cup supply	25
2.1 Information for the Maintenance Technician	7	7.6	First start-up of the vending machine	26
2.2 Description and intended use	8	7.7	Filling the boiler manually	26
2.3 Vending Machine Identification	8	7.8	Use of the vending machine	26
2.4.a Technical specifications Cristallo 600	9	8 PROGRAMMING AND MAINTENANCE MENU	27	
2.4.b Technical specifications Cristallo 400	10	8.1	Key description of programming and maintenance phases	27
3 SAFETY	11	8.2	Programming menu	27
3.1 Introduction	11	8.2.1	Entering the programming menu	27
3.2 General safety regulations	11	8.2.2	Structure of the programming menu	28
3.3 Operators' requirements	11	8.2.3	Description of messages in the programming menu	30
3.4 Safety devices	12	8.3	Maintenance menu	43
3.5 Residual risks	12	8.3.1	Entering the maintenance menu	43
4 HANDLING AND STORAGE	13	8.3.2	Structure of the maintenance menu	44
4.1 Unloading and handling	13	8.3.3	Description of messages in the maintenance menu	44
4.2 Storage	13	9 OPERATION AND USE	48	
5 INSTALLATION..... 14		9.1	Beverage selection	48
5.1 Important	14	10 CLEANING AND MAINTENANCE.. 49		
5.2 Unpacking and positioning	14	10.1	General notes for correct operation	49
5.3 Use of different-sized stirrers	16	10.2	Cleaning and scheduled maintenance	49
5.4 Label application	17	10.2.1	Maintenance schedule	49
5.5 Fitting the coffee grounds bag	18	10.2.2	Drip tray cleaning	50
5.6 Connection to serial port	18	10.2.3	Replacement of the coffee ground bag	50
5.7 Fitting the payment systems	18	10.2.4	Emptying the fluid discharge tank	50
5.8 Connection to water mains	19	10.2.5	Cleaning of the coffee brew group	51
5.9 Connection to the electric network	19	10.2.6	Cleaning the instant product dispenser and the mixer	51
6.A CONTROLS DESCRIPTION CRISTALLO 600	20	10.2.7	Cleaning the dispensing outlet	53
6.1.a Display	20	10.2.8	Cleaning the containers	53
6.2.a Keypad	20	10.2.9	Cleaning the dispensing arm	55
6.3.a Key description in standard operation mode	20	10.2.10	Cleaning the coffee grinder	56
6.4.a CPU card keys	20	10.2.11	Cleaning the sugar dispensing channel	56
6.B CONTROLS DESCRIPTION CRISTALLO 400	21	10.2.12	Cleaning the stirrer channel	56
6.1.b Display	21	10.3	Non-scheduled maintenance	57
6.2.b Keypad	21	10.4	Software updating	58
6.3.b Key description in standard operation mode	21	11 DISPLAY MESSAGES	59	
6.4.b CPU card keys	21	11.1	Messages during operation	59
		11.2	Error messages	59
		12 STORAGE - DISPOSAL	61	
		12.1	Change of location	61
		12.2	Inactivity and storage periods	61
		13 INSTRUCTIONS FOR END-OF-LIFE DISPOSAL TREATMENT	62	

1 INTRODUCTION TO THE MANUAL

1.1 Introduction



Important

This publication is an integral part of the vending machine and must be read carefully to ensure the machine is used correctly and in compliance with essential safety requirements.

This manual contains the technical information required for the correct use, installation, cleaning, and maintenance of the vending machine model **CRISTALLO 400/CRISTALLO 600**. Always refer to this publication before carrying out any operation.

Manufacturer: SAECO Vending S.p.A.

Località Casona, 1066 - 40041 Gaggio Montano
Bologna, Italy

This publication should be kept carefully, together with the vending machine throughout its operational life, even in case of changes of ownership.

Should this manual be lost or worn out, a copy can be requested from the Manufacturer or an Authorized Customer Service Centre by indicating all data on the identification plate on the back of the vending machine.

All the images in this manual refer to the **CRISTALLO 600** model.

The data that refers to a single model is indicated.

1.2 Symbols used

This publication contains various warnings which indicate different degrees of danger or skills required.

The symbol is integrated with a message suggesting use procedures or actions and providing useful information for the correct operation of the machine.



Warning

Indicates dangerous situations for the users, supply operators and maintenance technicians dealing either with the vending machine or the product to be dispensed.



Important

Indicates the operations for keeping the vending machine in good working order.



Recommended solutions

Indicates alternative procedures that make the programming and/or maintenance operations quicker.



User

Indicates the user of the vending machine. This person is not authorized to carry out any cleaning or maintenance operation.



Supply operator

Indicates operations to be carried out only by personnel in charge of supplying and cleaning the vending machine. Maintenance operations requiring a Maintenance Technician are not to be performed by the supply operator.



Maintenance Technician

Indicates operations to be carried out by qualified personnel in charge of maintenance.

The Maintenance Technician is the only person authorized to keep the MICROSWITCH ENABLING KEY, by which the security systems can be disabled.

2 INFORMATION ON THE VENDING MACHINE

2.1 Information for the Maintenance Technician

The vending machine must be installed in a well-lit, dry area, away from bad weather and dust, on a floor suitable to support its weight.

To guarantee the correct operation and reliability over time, the following is recommended:

- ambient temperature: from +1°C to +32°C;
- maximum humidity: 90% (not condensed).

For special installations not covered in this publication, please contact the dealer or the local importer. If this is not possible, please contact the Manufacturer directly.

AUTHORIZED CUSTOMER SERVICE CENTRES are available for information and explanations about the vending machine, and to provide technical assistance or spare parts.

The Maintenance Technician must carefully read and respect the safety warnings contained in this manual so that every intervention concerning installation, starting up, use and maintenance will be safely carried out.

It is the Maintenance Technician's absolute responsibility to give the keys to access the inside of the vending machine to another operator (Supply Operator), provided that the Maintenance Technician bears full responsibility for all work carried out.

This manual is an integral part of the machine and must be always read carefully before performing any operation.

2.2 Description and intended use

The vending machine is intended for automatic distribution of coffee and hot beverages (decaffeinated coffee, cappuccino, chocolate, etc.) and is programmable for every single type of dispensing dosage. The instant products must be consumed immediately, and cannot be preserved for a long time.

Any other use is to be considered improper and therefore dangerous.

Do not place any product inside the distributor which may be dangerous as a result of unsuitable temperatures.

Important

Improper use of the vending machine invalidates all warranties. The Manufacturer declines any liability for damage to property or injury to persons. Improper use also includes:

- any use of the vending machine other than the intended use and/or according to procedures which are not described in this publication;
- any intervention on the vending machine which differs from the instructions given in this publication;
- any alteration of components and/or safety devices without prior consent of the Manufacturer or carried out by personnel not authorized for such operations;
- any location of the appliance which is not recommended in this manual.

2.3 Vending Machine Identification

The vending machine is identified by the name, model and serial number which can be found on the relevant data plate (Fig. 2).



Fig. 2

The following data can be found on the plate:

- name of Manufacturer;
- marks of compliance;
- model;
- serial number;
- year and month of manufacture;
- supply voltage (V);
- supply frequency (Hz);
- electrical power consumption (W).



Warning

It is strictly forbidden to tamper with or modify the data plate.



Important

When contacting the AUTHORIZED CUSTOMER SERVICE CENTRES always refer to this plate and its relevant data.

2.4.a Technical specifications Cristallo 600

Weight: 105 kg
Overall dimensions: see figure 3



Fig. 3

Power consumption: see data plate
Supply voltage: see data plate
Electric voltage frequency: see data plate
Power cord length: 1,600 mm
Water mains connection: 3/4" Gas type
Water mains pressure: see figure 4
A-Weighted sound pressure level: less than 70 dB

Data plate showing minimum and maximum water supply pressure



Fig. 4

Container capacity

Coffee beans: 4,2 kg
Decaffeinated coffee: 1 kg
Chocolate: 3 kg
Milk: 2,5 kg
Lemon tea: 3 kg
Barley 1 kg
Sugar: 4,5 kg
Cups: No. 550
Stirrers: No. 550

Stirrer size

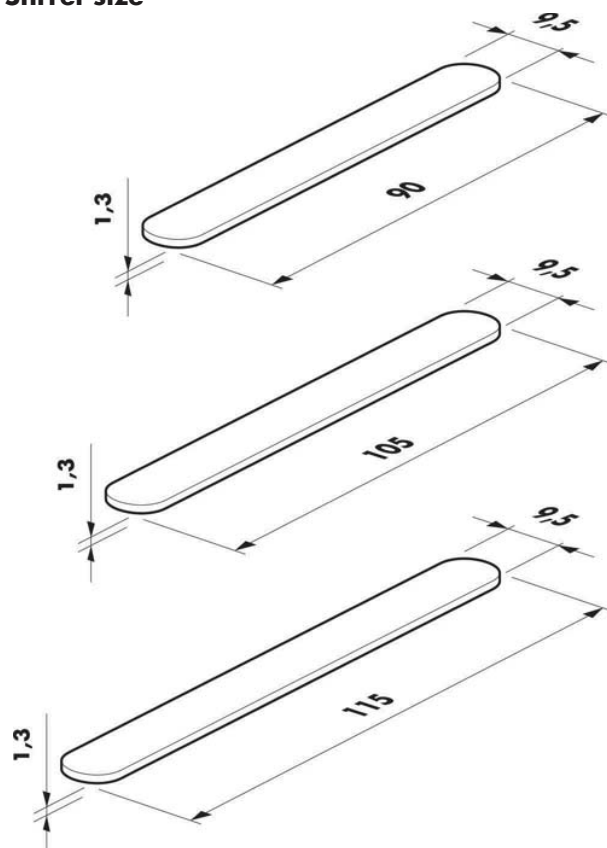

Fig. 5

2.4.b Technical specifications Cristallo 400

Weight: 97 kg

Overall dimensions: see figure 3



Fig. 3

Power consumption: see data plate

Supply voltage: see data plate

Electric voltage frequency: see data plate

Power cord length: 1,600 mm

Water mains connection: 3/4" Gas type

Water mains pressure: see figure 4

A-Weighted sound pressure level: less than 70 dB

Data plate showing minimum and maximum water supply pressure



Fig. 4

Container capacity

Coffee beans: 3.5 kg

Decaffeinated coffee: 1 kg

Chocolate: 3 kg

Milk: 2.5 kg

Lemon tea: 3 kg

Sugar: 3 kg

Cups: No. 400

Stirrers: No. 400

Stirrer size

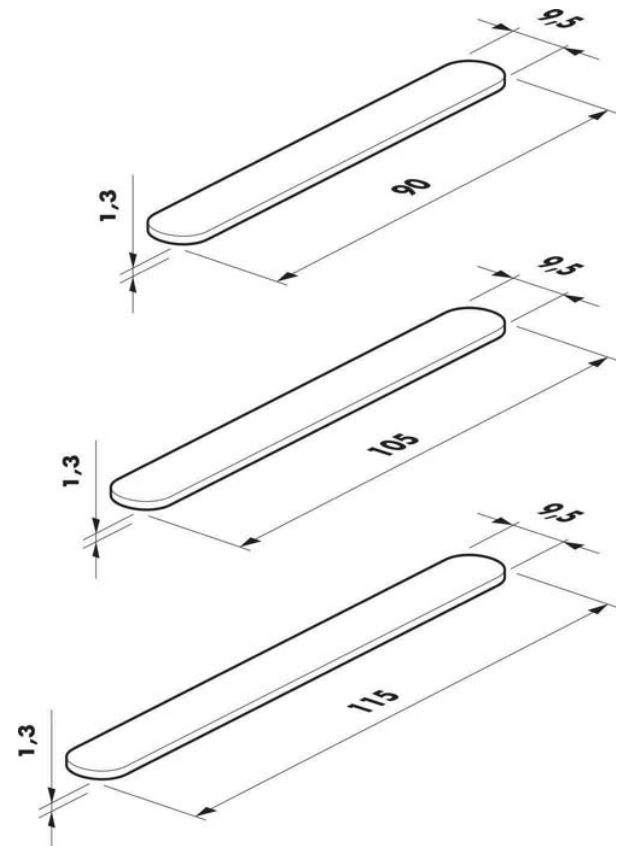

Fig. 5

3 SAFETY

3.1 Introduction

In compliance with the Low Tension Directive 2006/95/EC (which replaces the directive 73/23/EEC and following amendments) and CE Marking Directive 93/68/EEC, SAECO Vending has drawn up a technical file of the CRISTALLO 400 e CRISTALLO 600 vending machine held at its plants. The following regulations were taken into account during the design phase:

- EN 55014
- EN 61000-3-2
- EN 61000-3-3
- EN 61000-4-2
- EN 61000-4-3
- EN 61000-4-4
- EN 61000-4-5
- EN 61000-4-11
- EN 60335-2-75
- EN 60335-1

3.2 General safety regulations

It is forbidden to:

- tamper with or disable the safety systems installed on the vending machine;
- carry out maintenance on the vending machine without unplugging it first;
- install the vending machine outdoors. It should be placed in dry areas where the temperature never falls below 1°C;
- use the vending machine for purposes other than those indicated in the sale contract and in this publication;
- connect the appliance to the mains using multi-sockets or adapters;
- use water jets to clean the vending machine (Fig. 6).



Fig. 6

It is compulsory to:

- check the electrical power line for conformity;
- use original spare parts;
- read the instructions contained in this publication and in the enclosed documents carefully;
- use personal protection devices during installation, testing and maintenance operations.

Precautions for preventing human errors:

- make the operators aware of safety issues;
- handle the vending machine, either packaged or unpackaged, in safe conditions;
- have a thorough knowledge of the installation procedures, its operation and limits;
- dismantle the vending machine in safe conditions, in accordance with the environmental protection and health and safety laws in force.



Warning

In case of failure or malfunctioning contact only qualified CUSTOMER SERVICE personnel.



Important

The Manufacturer declines any liability for any damage caused to property or injury caused to persons as a result of failure to observe the safety regulations described here.

3.3 Operators' requirements

Three operators with different skills are required in order to guarantee the safety of the vending machine:



User

Access to the internal part of the vending machine is forbidden to the user.



Supply operator

The Maintenance Technician assigns the safekeeping of the access key to the Supply operator who is in charge of product supply, external cleaning, and starting up / stopping of the vending machine.



Warning

The Supply Operator is not authorized to carry out operations which are indicated as being the duties of the Maintenance Technician in this publication.



Maintenance Technician

The Maintenance Technician is the only person authorized to intervene and start programming procedures, and perform adjusting, setting up and maintenance operations on the vending machine.

3.4 Safety devices

The vending machine is equipped with:

- a safety switch (ref. 11) on the upper door, which cuts off voltage to all inside components, whenever the front or upper (Cristallo 400) door is opened;
- a switch (ref. 26) indicates (when safety key is inserted) that the vending machine door is open;
- a safety switch located on the dispensing outlet door, which blocks the nozzle arm cycle whenever the door is opened.



Maintenance Technician

In case of programming or setting up operations only the Maintenance Technician can intervene by inserting the relevant key into the safety switch (Fig. 7) and resetting the voltage even if the door is open.



Fig. 7



Warning

This operation, necessary for starting up the vending machine, disables the safety system.

It must therefore be carried out by qualified personnel (Maintenance Technician) aware of the risks resulting from the presence of live or moving components.

3.5 Residual risks

The dispensing outlet is protected by the door interlocked by the safety switch.

If it is opened during the brewing cycle, mechanical movement is blocked, but if brewing has already started, it continues up to the end of the cycle.



Warning

Risk of scalding if hands are placed inside the outlet during brewing.

It is forbidden to open the door and take out the cup or put hands inside the outlet during dispensing, before the brewing cycle is complete (Fig. 8).

Before removing the cup from the outlet, please wait for the message "REMOVE CUP" on display.



Fig. 8



Important

If the outlet door is opened during the brewing cycle, the message "CLOSE SERVICE DOOR" will be displayed; the nozzle arm stops and will not restart until the door is closed.

It is not possible to brew further beverages if the previous cup is not taken out (see the "Dispensing outlet microswitch" menu item).

Before brewing another beverage, check that the previous one has been taken out and that the cup support is empty.

4 HANDLING AND STORAGE

4.1 Unloading and handling

Unloading and handling operations after transportation must be carried out only by qualified personnel and using suitable equipment.

The vending machine is placed on a pallet, protected by a sack, by a shrink film and four angle bars (Fig. 9).



Fig. 9

Use a fork-lift to unload the vending machine from the transport vehicle (Fig. 10).



Fig. 10



Warning

The vending machine must always be kept in the upright position. Avoid:

- dragging the vending machine;
- overturning or laying the vending machine flat during transport and handling;
- shaking the vending machine;
- lifting the vending machine with ropes or cranes;
- leaving the vending machine exposed to the elements, in humid areas or close to heat sources.

4.2 Storage

If the vending machine is not installed immediately, it should be stored in a sheltered area, conforming to the following instructions:

- the packaged vending machine must be stored in a closed, dry area at a temperature between 1°C and 40°C;
- do not put other appliances or boxes on the vending machine (Fig. 11);
- it is always good practice to protect the vending machine from any deposits of dust or other material.

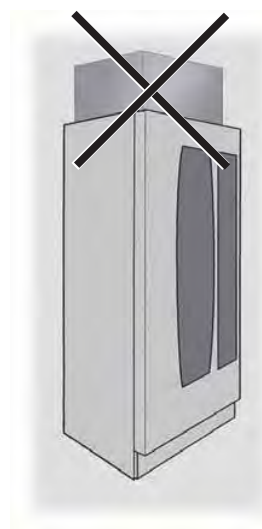

Fig. 11

5 INSTALLATION

5.1 Important



Warning

The vending machine cannot be installed outdoors; avoid placing it in areas where the temperature is less than 1°C or more than 32°C and in particularly damp or dusty areas.

Positioning operations require at least 2 operators.

Before unpacking, check that the installation area complies with the following specifications:

- the power socket must be located in an easily accessible area, not more than 1.5 meters away;
- the socket voltage must comply with that on the identification plate;
- the surface or floor must NOT have a gradient of more than 2°.

If the vending machine needs to be positioned close to a wall, it is necessary to leave a space of at least 15 cm between the back and the wall in order to keep the air outlet grille free (Fig. 12).

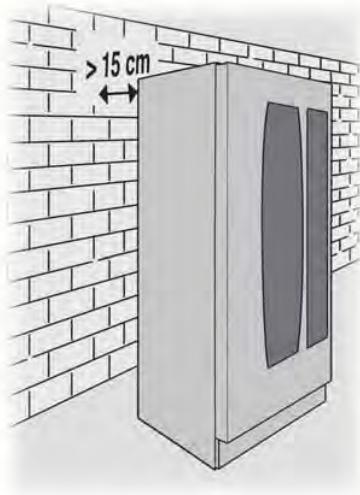

Fig. 12

5.2 Unpacking and positioning



On receipt of the vending machine make sure that it has not been damaged during transportation and that package has not been tampered with or that internal parts have not been removed.

14

An envelope, called "CUSTOMER KIT" is supplied with the vending machine; it contains the objects shown in Fig. 13.



Fig. 13

Remove the transparent protective film and the four angle bars (Fig. 14).



Fig. 14

If damage of any kind is found, the courier must be informed and notice must be given to the importer or the seller immediately. If these are not in the purchaser's country, please contact the manufacturing company directly.

From the discharge tank, take out the accessory packet containing the following items:

- 4 feet;
- 1 key for the brew group;
- 1 cap for the coffee grinder.

Lift the pallet in a way that the four fixing **A** screws can be removed (Fig. 15).

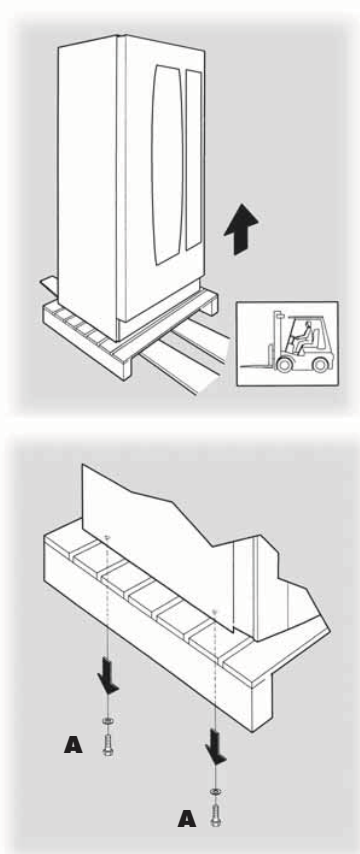

Fig. 15

To lift the pallet so that the four supporting **B** feet can be screwed on (Fig. 16), it is necessary to remove the skirting (Fig. 17 and 18) by loosening the two screws and unlocking it.

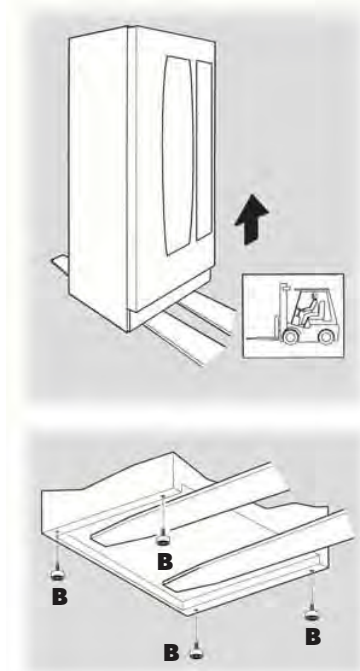

Fig. 16

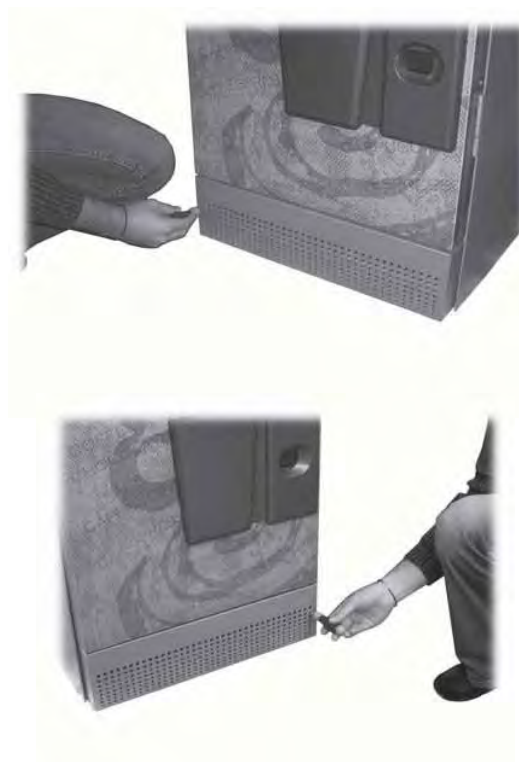

Fig. 17



Fig. 18

Adjust the levelling using the relevant feet (Fig. 19).

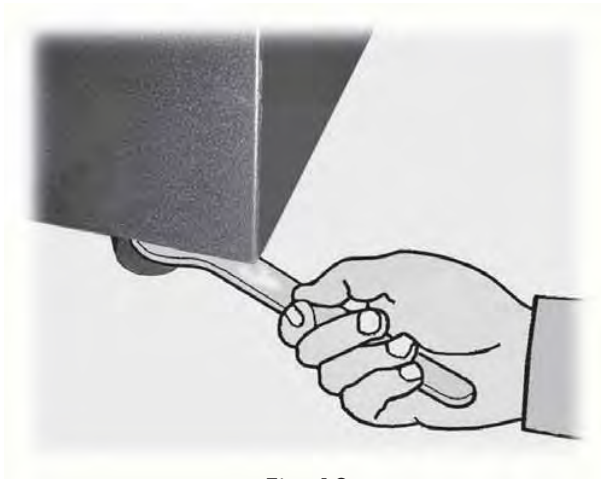

Fig. 19

Take out the keys from the change slot (Fig. 20).



Fig. 20

Insert the key into the lock, turn clockwise and open the door (Fig. 21).



Fig. 21

5.3 Use of different-sized stirrers



The vending machine is delivered with the stirrer set designed for use of 90 mm stirrers.



Warning

If 90 mm stirrers are used, make sure that the rubber pin (Fig. 22) is inserted in the hole (Fig. 23).



Fig. 22



Fig. 23

To substitute the 90 mm stirrers with those of 105 mm or 115 mm proceed as follows:

- Unfasten the two screws fixing the stirrer guide (Fig. 24 and 25);

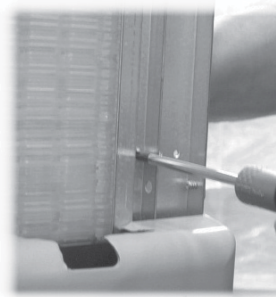

Fig. 24



Fig. 25

- Move the stirrer guide into the hole (Fig. 26) corresponding to the desired dimension and tighten the two screws.

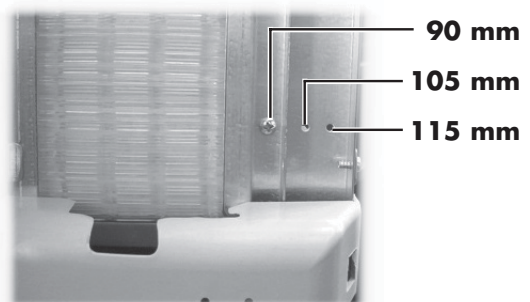

Fig. 26

5.4 Label application

Product labels

Remove the cup dispenser and unscrew the 4 knobs holding the keypad panel in place.

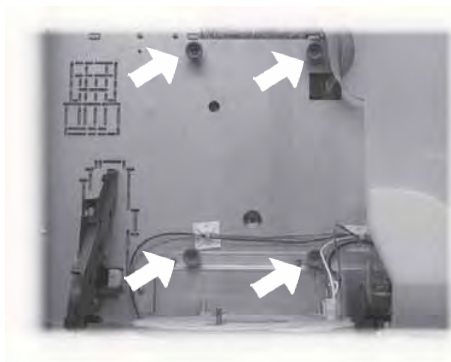
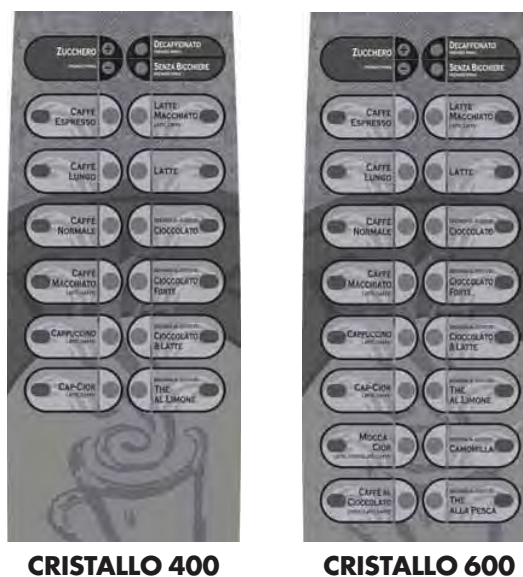

Fig. 27

Check the exact position of the labels against the selection key (Fig. 30).



CRISTALLO 400

CRISTALLO 600

Fig. 30

Open the keypad panel (Fig. 28).



Fig. 28

Instruction plate

Insert the instruction plate into the slot (Fig. 31). The keypad panel must be open in order to perform this operation. Otherwise, please see instructions in "Product labels".

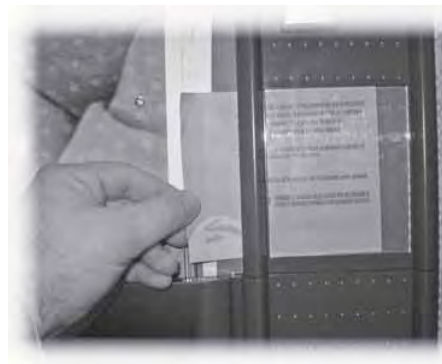

Fig. 31

Insert the product labels (Fig. 29).



Fig. 29

Coin box label

Insert the coin box label into the slot (Fig. 32).



Fig. 32

5.5 Fitting the coffee grounds bag



Remove the clip from the grounds discharge channel (Fig. 33).



Fig. 33

Slip the clip into the coffee grounds bag (capacity of 50 litres) (Fig. 34).



Fig. 34

Place the bag on the channel (Fig. 35).



Fig. 35

5.6 Connection to serial port



By means of a CPU connector and an interface kit, the vending machine can be connected to a Personal Computer or to appliances supplied by AUTHORIZED CUSTOMER SERVICE CENTRES, to carry data collection operations.

5.7 Fitting the payment systems



The vending machine is designed for the installation of various payment systems, such as:

- parallel banknote reader 24V DC;
- parallel coiner 24V DC;
- executive systems (also PRICE HOLDING);
- MDB systems;
- BDV systems;
- cancelling machine 24V DC;
- parallel banknote reader 12V DC(*);
- parallel coiner 12V DC (*);
- tokens acceptor 12V DC (*);
- Saeco card (**);

(*) with optional feeder only.

(**) only 1432 and 1471 models require optional feeder.

Important

The vending machine is not supplied with any payment system, which must be installed by the person in charge of its fitting.

After the chosen payment system has been installed, the corresponding parameters can be set through the programming menu (see 8.2).

Using the adhesive paper template (available in the "Saeco Card assembly Kit"), drill the holes for the installation of the external antenna of Saeco Card payment system. It is recommended to drill the holes in the area for Cashless systems (Fig. 36).



Fig. 36

**Warning**

The Manufacturer declines any liability for any damage to the vending machine, to property and/or injury to persons, caused by the installation of the payment system. The responsibility falls to the person who carried out the installation.

5.8 Connection to water mains**Important**

It is recommended to use a descaling device for the water network supplying the vending machine, especially for water with a high calcium and magnesium content (hard water). Connect the vending machine to a drinking water supply pipe with a pressure ranging between 1.5 and 8 bars (see data plate).

Remove the cap from the coupling placed on the vending machine back panel (Fig. 37). Connect the water supply pipe to the 3/4" Gas coupling of the vending machine (Fig. 37).

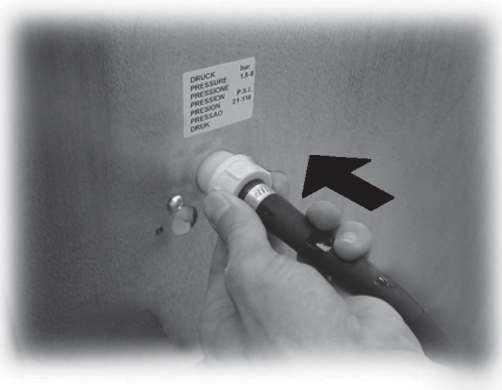

Fig. 37

5.9 Connection to the electric network**Warning**

The Maintenance Technician, who is responsible for the installation of the vending machine, must ensure that:

- the electric system complies with current safety regulations;
- the supply voltage corresponds to that indicated on the data plate.

If in doubt, do not proceed with the installation and ask qualified and authorized personnel to check the system accurately.

The vending machine is equipped with a power cord which must be plugged into the appropriate socket on the vending machine back panel (Fig. 38).



Fig. 38

Do not use adapters or multi-sockets (Fig. 39).



Fig. 39

6.a CONTROLS DESCRIPTION CRISTALLO 600

6.1.a Display

The display (2 - Fig. 1) shows the messages during standard operation, programming and maintenance modes.

6.2.a Keypad

Important

Each key function changes according to the vending machine mode (ordinary dispensing or programming mode).

Each key has a double function that varies according to the vending machine status (standard operation or programming).

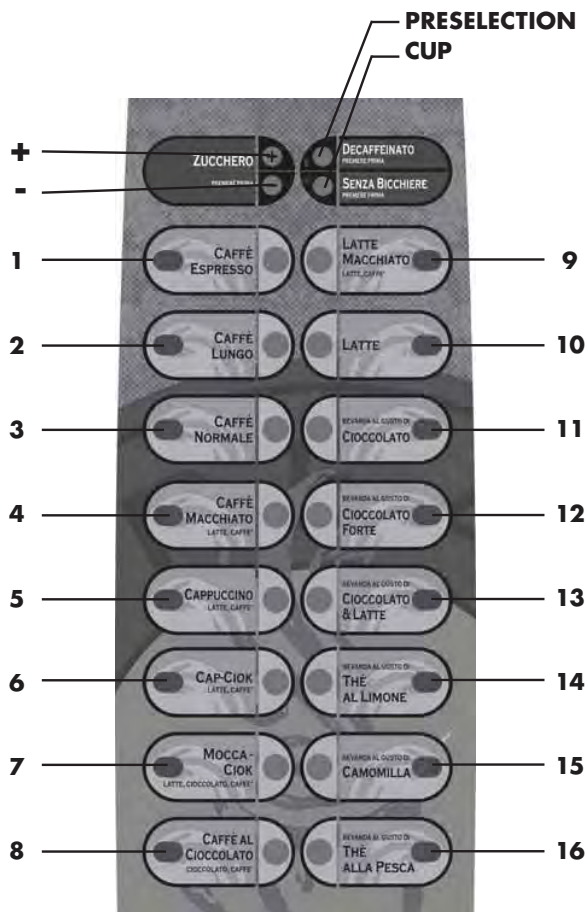

Fig. 40

6.3.a Key description in standard operation mode

"+" Key - Sugar Quantity (Fig. 40)

Increases the quantity of sugar in the selected beverage. Press the key before selecting the beverage. The preselection remains active for 8 seconds.

"-" Key - Sugar Quantity (Fig. 40)

Decreases the quantity of sugar in the selected beverage. Press the key before selecting the beverage. The preselection remains active for 8 seconds.

Preselection Key (Fig. 40)

The functions associated with the preselection key can be selected from the following:

- A. Preselection 19-34
- B. Beverage 17
- C. Disabled

Cup Key (Fig. 40)

The functions associated with the cup key can be selected from the following:

- A. Preselection cup
- B. Beverage 18
- C. Preselection 35-50
- D. Disabled

Keys (1 to 16 - Fig. 40)

By pressing these keys, the programmed beverages are dispensed.

6.4.a CPU card keys

The CPU electronic card has three keys enabling the Maintenance Technician to carry out programming or maintenance operations (Fig. 41).

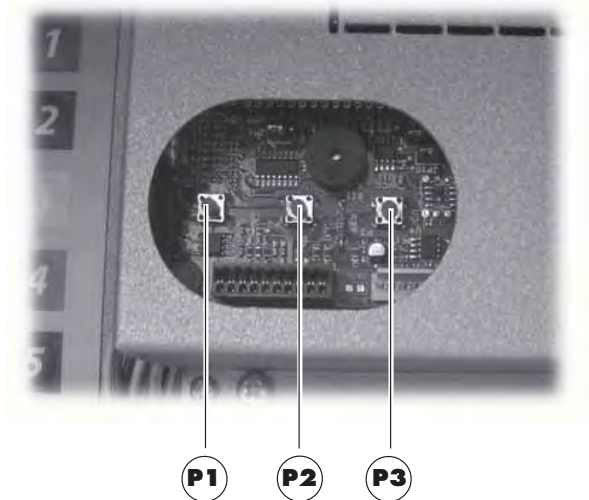

Fig. 41

6.b CONTROLS DESCRIPTION CRISTALLO 400

6.1.b Display

The display (2 - Fig. 1) shows the messages during standard operation, programming and maintenance modes.

6.2.b Keypad

Important

Each key function changes according to the vending machine mode (ordinary dispensing or programming mode).

Each key has a double function that varies according to the vending machine status (standard operation or programming).

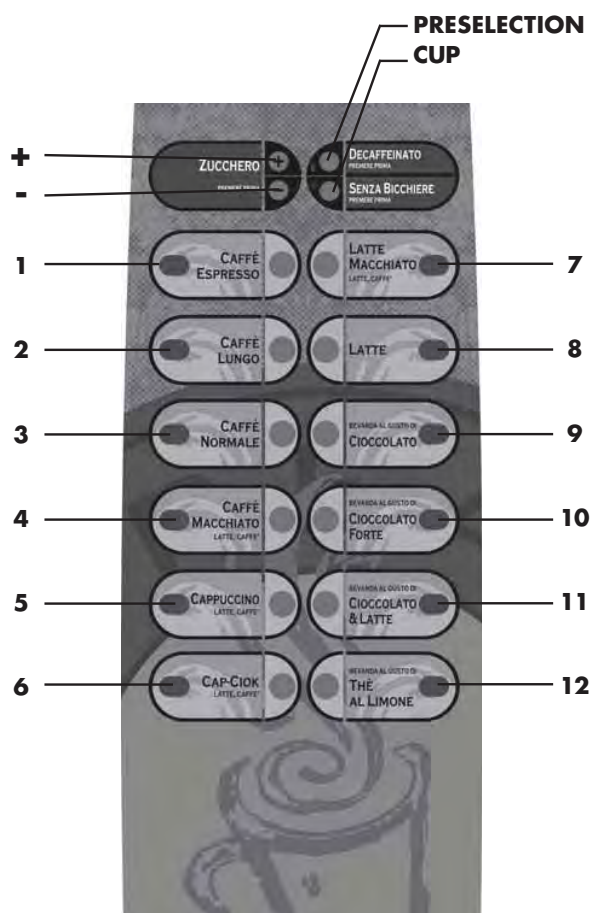

Fig. 40

6.3.b Key description in standard operation mode

“+” Key - Sugar Quantity (Fig. 40)

Increases the quantity of sugar in the selected beverage. Press the key before selecting the beverage.

The preselection remains active for 8 seconds.

“-” Key - Sugar Quantity (Fig. 40)

Decreases the quantity of sugar in the selected beverage. Press the key before selecting the beverage.

The preselection remains active for 8 seconds.

Preselection Key (Fig. 40)

The functions associated with the preselection key can be selected from the following:

- A. Preselection 15-26
- B. Beverage 13
- C. Disabled

Cup Key (Fig. 40)

The functions associated with the cup key can be selected from the following:

- A. Preselection cup
- B. Beverage 14
- C. Preselection 27-38
- D. Disabled

Keys (1 to 12 - Fig. 40)

By pressing these keys, the programmed beverages are dispensed.

6.4.b CPU card keys

The CPU electronic card has three keys enabling the Maintenance Technician to carry out programming or maintenance operations (Fig. 41).

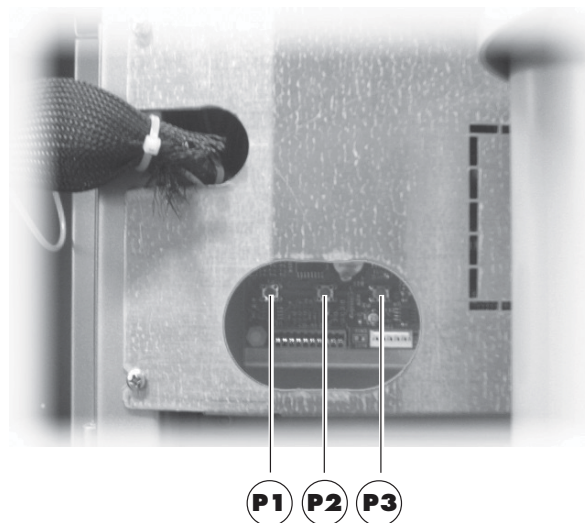

Fig. 41

7 SUPPLY AND STARTING UP

7.1 Container supply



Important

The containers delivered are designed to dispense the following products (Fig. 43):

- Instant product 1** = Tea
- Instant product 2** = Milk
- Instant product 3** = Chocolate
- Instant product 4** = Decaffeinated coffee
- Instant product 5** = Barley (not Cristallo 400)



Fig. 42

7.1.1 Instant product supply



Open the cover of the container to be supplied (Fig. 43).



Fig. 43

Pour the instant product into the container (Fig. 44).



Fig. 44

Close the container cover.

7.1.2 Sugar supply



Open the sugar container cover and pour sugar into the container (Fig. 45).



Fig. 45

Close the container cover.

7.1.3 Coffee bean supply



Remove the container cover (Fig. 46).



Fig. 46

Put coffee beans into the container (Fig. 47).



Fig. 47

Replace the cover on the container.



Important

If the message "COFFEE NOT AVAILABLE" is displayed after the supply, the following operations should be carried out:

- press the **P2** key (Fig. 41) to enter the maintenance menu;
- press the key "**e**" twice (**PRESELECTION** - Fig. 40) to eliminate the error (see sect. 8.3.3 Description of messages in the maintenance menu).

7.2 Dose calibration



The vending machine is delivered with standard calibration values set by the manufacturer. The quantity of coffee powder is set to 7.0 gr.

Dose calibration can be performed by means of two calibration levels:

- remove the cover (Fig. 48);
- release the adjusting lever from the rack and place



Fig. 48

- the dragging tooth of the inner panel on one of the 4 positions available, which indicate the basic quantity area (6 gr. - 7 gr. - 8 gr. - 9 gr.) (Fig. 49);

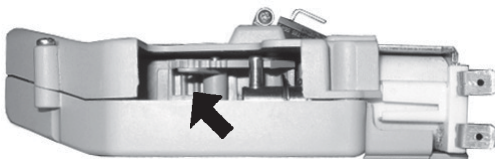

Fig. 49

- move the adjusting lever into the rack and select the slot corresponding to the dose required (Fig. 50).

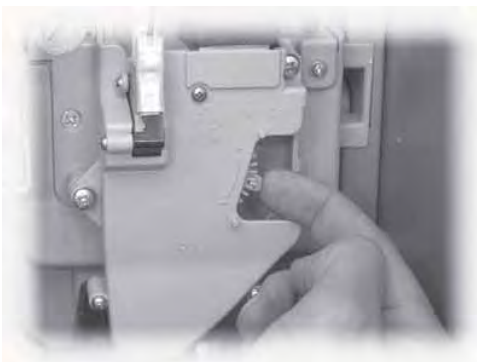

Fig. 50

7.3 Coffee grinding calibration



Turn the ring (Fig. 51) until the required results are obtained. After any calibration three selections are necessary before the new setting becomes effective.

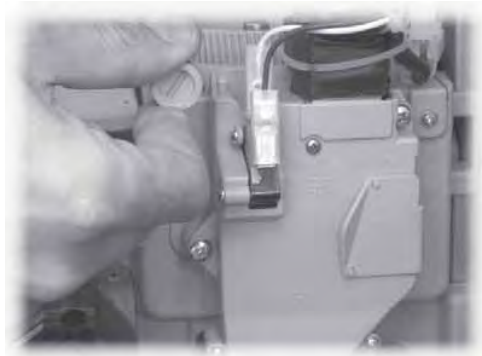

Fig. 51

7.4 Stirrer supply



Important

Use stirrers suitable for automatic vending, without imperfections and conforming to the dimensions indicated in 2.4 Technical Specifications.

- Remove the metal counterweight from the stirrer guides (fig. 52).



Fig. 52

- Introduce the stirrers with their packing band into the column (fig.53); once they are placed on the bottom, cut and remove the band (fig. 54).



Fig. 53



Fig. 54

- When loading is complete, reinsert the metal counterweight (fig.55).



Fig. 55

Make sure the stirrers have no burrs, are not bent and are all placed horizontally.

7.5 Cup supply



Use only cups suitable for automatic vending - 70-71 mm diameter - and avoid compressing them while loading.

Important

Do not try to turn the column manually.

When installing, with the cup dispenser empty, proceed as follows:

- remove the cover of the cup dispensing tube (fig.56).



Fig. 56

- load two of the most accessible tubes (fig. 57).



Fig. 57

- replace the cover on the cup columns.

7.6 First start-up of the vending machine



Supply the vending machine (following the instructions given previously) and plug it into the power supply (see 5.9).

At this point the message "CRISTALLO 600/CRISTALLO 400" will be displayed and the self-configuration is enabled which controls all the previously defined settings, such as:

- the presence of the TIMEKEEPER;
- the correct position of the dispensing arm.

Any faults detected during the self-configuration cycle are stored so that the vending machine can display them at the end of the self diagnostic phase.

Adjust grinding as instructed in 7.3; the boiler must be necessarily filled.

7.7 Filling the boiler manually



Manual filling of the boiler is required during the first start-up of the vending machine.

After switching on the vending machine it is possible to fill the boiler following one of the following procedures:

- a) - press the **P2** key (Fig. 41) to enter the maintenance menu;
 - press the "e" key (**PRESELECTION** - Fig. 40) followed by the UP key (+ - Fig. 40) to access the RINSING entry;
 - press the "e" key (**PRESELECTION** - Fig. 40) to carry out the automatic complete rinsing cycle.
- b) - press the **P2** key (Fig. 41) to enter the maintenance menu;
 - press the "e" key (**PRESELECTION** - Fig. 40) followed by the UP key (+ - Fig. 40) to access the RINSING entry;
 - press the keys **1, 2, 3, 4**, etc. (beverage keys) to perform the rinsing cycle of any single circuit.
- c) - press key 1 (Fig. 41) to enter the programming menu;
 - press the P1 and P2 keys simultaneously (Fig. 41) on the CPU card to carry out the rinsing.



Important

The rinsing operation must be repeated until water flows out of the brewing nozzles regularly.

7.8 Use of the vending machine



Important

The instructions for use are shown on the plate on the front of the vending machine.

The beverage selection procedures are shown in section 9.

8 PROGRAMMING AND MAINTENANCE MENU

Important

This section illustrates how to set up or modify the vending machine programming and maintenance settings.

It is therefore necessary to read it carefully, and intervene only when the correct sequence of operations to be performed is fully understood.

8.1 Key description of programming and maintenance phases

To scroll through the vending machine menu, the keys described below are used.

“e” Key: ENTER (4 - Fig. 58)

By pressing this key it is possible to enter the following programming or maintenance level. It is also possible to modify or confirm the values set in the entries of the programming or maintenance menus.

“c” Key: CANCEL (3 - Fig. 58)

By pressing this key it is possible to go back to the previous level of the programming or maintenance menu. It is also possible to avoid storing the previously modified values.

“V” Key: DOWN (2 - Fig. 58)

Pressing this key it is possible to access the previous entry inside the same level.

If used after a setting modification request, the value of this setting decreases.

“^”Key: UP (1 - Fig. 58)

By pressing this key it is possible to access the next entry inside the same level.

If used after requesting the change of a setting, the value of this setting increases.

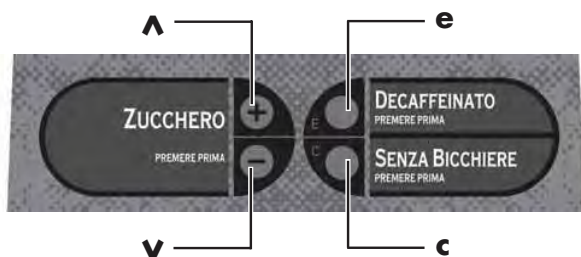

Fig. 58

8.2 Programming menu

The structure of the programming menu is shown in 8.2.2. 8.2.3 describes all the entries in the programming menu.

8.2.1 Entering the programming menu

Open the door, disable the safety device (see 3.4) and press the P1 key (Fig. 59) to enter the programming menu.

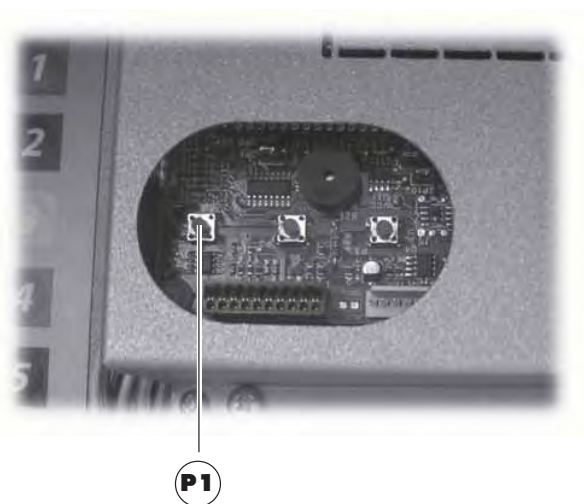

Fig. 59

If no password has been assigned, the programming menu is entered directly.

Important

If a password was assigned to the vending machine to enable the programming menu, the message “PASSWORD 000000” will appear on the display with a flashing cursor on the first digit.

Now the password should be entered using the UP and DOWN keys. Confirm the digit entered by pressing the ENTER key.

Proceed as follows to exit the programming menu and return to standard operation of the vending machine:

- press the **P1** key again;
- remove the key from the safety switch in order to turn off the vending machine;
- close the door and wait for the self-configuration process to end.

8.2.2 Structure of the programming menu

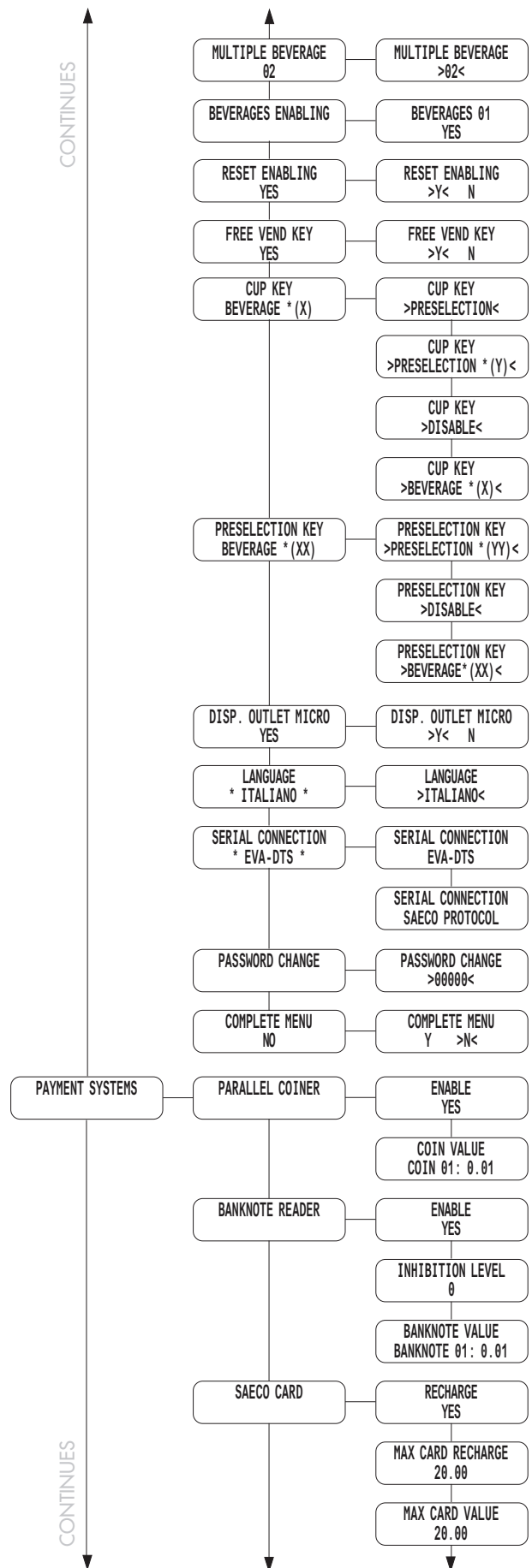
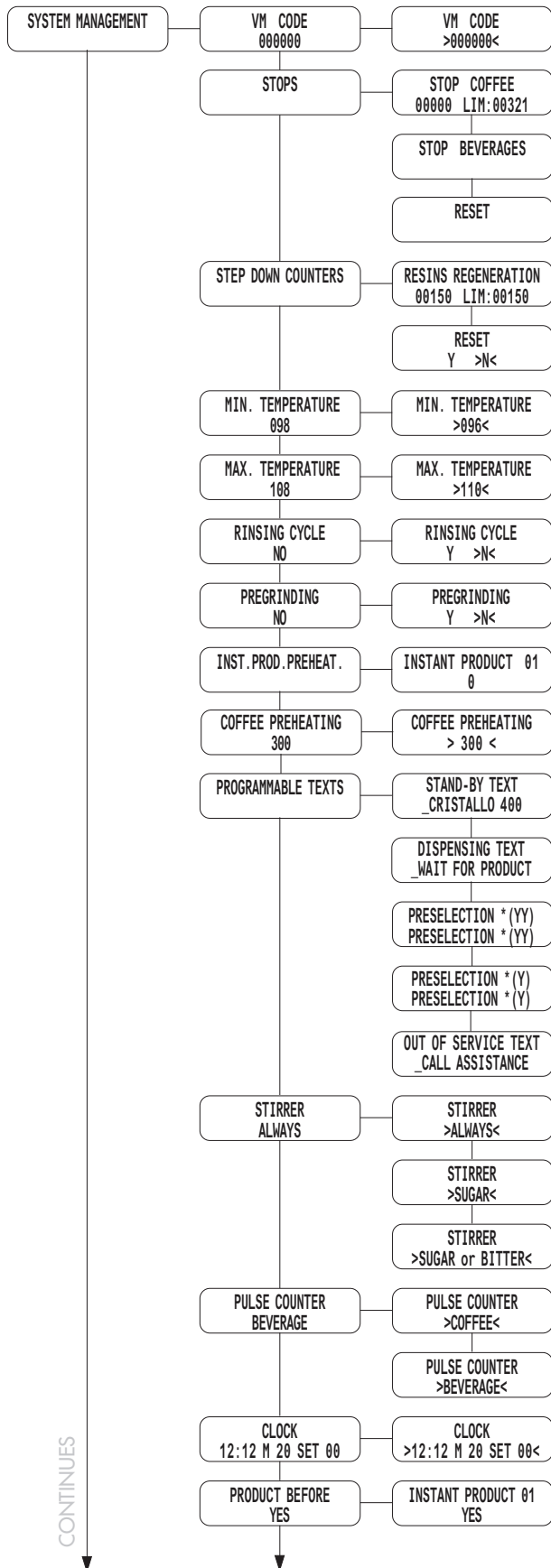

8.2.3 Description of messages in the programming menu



Important

Visible only if the complete menu option is enabled

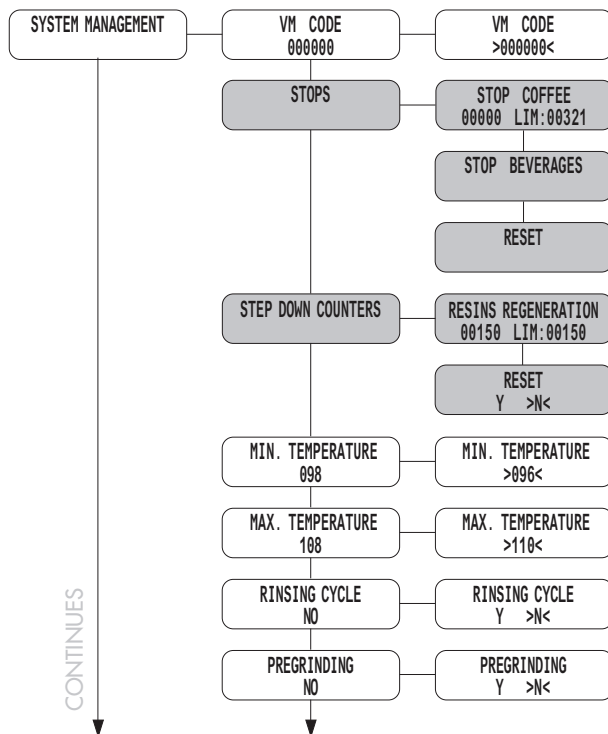

Important

The menu items are visible only if the option "Complete menu" is enabled and will be marked with the ("CM") abbreviation.

SYSTEM MANAGEMENT

The SYSTEM MANAGEMENT items are:

- VM Code

Enables an identification code to be assigned to the vending machine.

- Stops ("CM")

Enables setting of the maximum amount of beverage or coffee. Once the maximum amount is reached, the vending machine stops dispensing the relevant beverages. The first digit on the left ("00000") refers to the quantity of product dispensed since the last "RESET" (partial counters).

The right hand digit, preceded by "LIM", shows the maximum dispensable quantity (value may be modified).

• Stop coffee

Enables setting of the maximum number of coffee cups to be dispensed before the stop.

• Stop beverages

Enables setting of the maximum number of beverages to be dispensed before the stop.

• Reset

Enables resetting of all partial counters relative to product quantity stop functions.

- Step down counters

It allows setting a quantity of water which must be dispensed before the message of operation in the maintenance menu is received.

In the menu item, the value on the left (00150) shows the quantity of water that may be still dispensed, whereas the value on the right (LIM:00150) shows the set limit. The quantity is expressed in litres.

By dispensing water (for beverages or rinses) the counter on the left is decreased. When the value "0" is reached, the new item "STEP DOWN COUNTERS" will be displayed in the maintenance menu (WARNING 83 will be registered in the ERROR LOG).

- Min. temperature

Enables setting of the temperature to be maintained for a few minutes by the vending machine after a beverage has been dispensed. The set value is expressed in centigrade.

- Max. temperature

Enables setting of the temperature to which the vending machine is brought after a certain time from the last dispensing, in order to compensate for the natural decrease of the temperature of the hydraulic circuits. The set value is expressed in centigrade.

- Rinsing Cycle

It allows enabling of the automatic rinsing of the mixing bowls. The automatic rinsing is performed as follows: the first rinsing takes place 10 minutes after the "machine ready" status; if necessary, other rinses occur 7 hours after the last dispensing.

- Pre-grinding

Enables instant pre-grinding of the coffee dose.

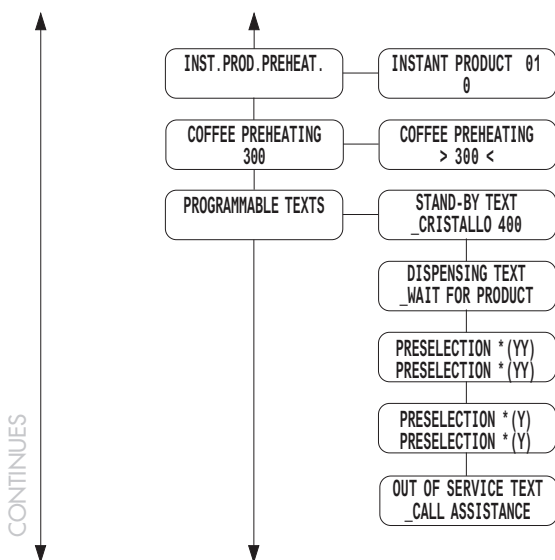

- Instant product preheating

Enables selection of the instant products for which the preheating function will be enabled. By enabling this function, the vending machine performs a preliminary dispensing of water through the circuit corresponding to the instant product selected. The user can choose for which instant product prerinsing can be enabled, by setting cu cm of water to be used.

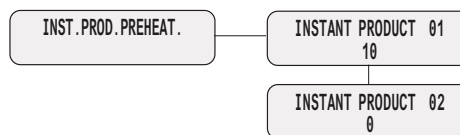

Example: the settings shown in the figure enable preheating for instant product 1 with 10 units of water and do not enable preheating for instant product 2.

Instant product preheating takes place if:

- at least 3 minutes have passed since the mixing bowl was last used;
- the quantity of water for the instant product is < 50 units.

- Coffee pre-heating

It allows enabling a pre-heating cycle of the Brew Group if it remains inactive for a period of time. This menu allows setting the seconds of inactivity after which the pre-heating cycle has to take place. The settable values are:

- 0 (zero) pre-heating cycle disabled,
- from 60 seconds to 900 seconds at intervals of 60.

The default value is 300.

- Programmable texts

STAND-BY TEXT: it enables setting the message appearing on the display when the vending machine is in standard operating mode.

DISPENSING TEXT: it allows setting the message appearing on the display when the vending machine is dispensing a product.

PRESELECTION TEXT *(YY): it allows setting the message appearing on the display when the preselection mode of the preselection key is active (Fig. 40).

	CRISTALLO 600	CRISTALLO 400
*(YY)	Preselection 19-34	Preselection 15-26

PRESELECTION TEXT *(Y): it allows setting the message appearing on the display when the preselection mode of the cup key is active (Fig. 40).

	CRISTALLO 600	CRISTALLO 400
*(Y)	Preselection 35-50	Preselection 27-38

OUT OF SERVICE TEXT: it enables setting the text on the display when the vending machine stops due to a fault.

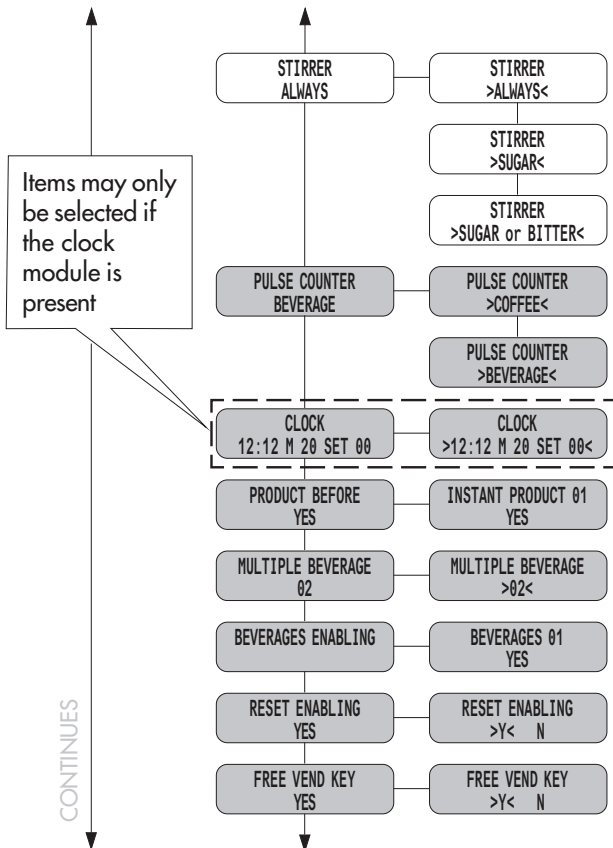

- **Stirrer**
Enables selection of the stirrer dispensing mode.
STIRRER ALWAYS: the stirrer is dispensed anyway;
STIRRER SUGAR: the stirrer is dispensed only if the beverage is served with sugar;
STIRRER SUGAR or BITTER: the stirrer is dispensed for all the beverages which should be served with sugar, although the user requires them without it.
- **Coffee / beverage pulse counter ("CM")**
Enables selection of whether the 24V dc electromechanical pulse counter (optional – to be connected to the CPU card) has to count the coffees or all dispensed beverages.
- **Clock** (visible if clock module is installed)
Enables setting of the hour, minute, day of the week, day of the month, month and year.
- **Product before ("CM")**
Enables selection of the instant product powder to be dispensed before water.
This brewing cycle will be carried out only if the quantity of powder to be brewed is below 34.
- **Multiple beverage ("CM")**
Enables selection of the beverages to be enabled for multiple dispensing and the maximum number of beverages dispensed.
The upper line will remain the same for all following operations, while the lower line will display the number of consecutive beverages. It is possible to set a value between 2 and 8.
- **Beverages enabling ("CM")**
It allows enabling or disabling of the beverage keys.
During standard operation the message "NOT AVAILABLE" will be displayed when a disabled key is pressed.
- **Reset enabling ("CM")**
It allows enabling of the "RESET" for data in the statistics maintenance menu.
- **Free vend key ("CM")**
It enables the P3 key (Fig. 41, ref. 3) of the CPU card for free dispensing of a product during standard operation.

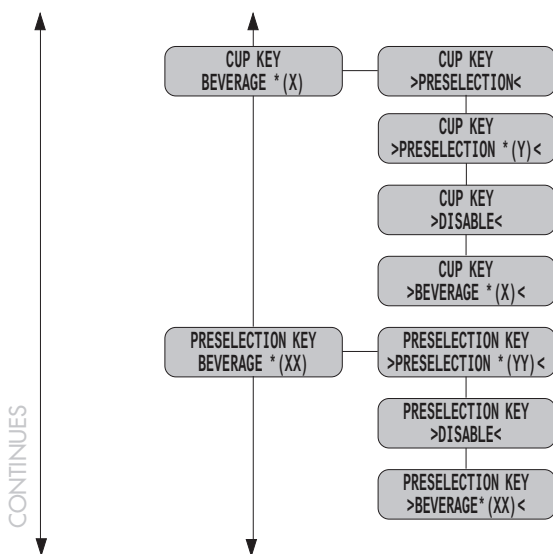

- Cup key ("CM")

The functions associated with the cup key can be selected from the following:

	CRISTALLO 600	CRISTALLO 400
A.	Preselection cup	Preselection cup
B. *(X)	Beverage 18	Beverage 14
C. *(Y)	Preselection 35-50	Preselection 27-38
D.	Disabled	Disabled

A - Preselection cup:

if this option is enabled, a beverage without cup can be obtained by pressing the CUP key before choosing a beverage. After the preselection key is pressed, the user has 8 seconds to select the desired product. After 8 seconds, the preselection is cancelled.

Price Setting - Cup price can be set only if cup preselection is activated. To set, go to PROGRAMMING - CUP PRICE in the PRICE MANAGEMENT menu.

Counters and Statistics - If cup preselection is activated, the VM will calculate the cost of the product based on two components: beverage + cup; the operator will therefore have to set the price of both components. The amount paid by the user for each product with cup is given by the sum of the beverage price plus the cup price. A practical example is given below.
If: price level 1 = 0.50 and price level 2 = 0.05

	Beverage Price	Cup Price	Final Cost	Increased Counters
Beverage with cup	Level 1	Level 2	0.55	Beverage counter and cup counter
Beverage without cup	Level 1	Level 2	0.50	Beverage counter

Beverage counter - If the product is dispensed with the cup, the following will be added to statistics:
1 stroke for the beverage at price level 1 (0.50), 1 price increase on cup price (0.05) and 1 cup dispensing.

Whereas if the product is dispensed without the cup, the following will be added to statistics:
1 stroke for the beverage at price level 1 (0.50) and 1 cup dispensed.
The total amount of cup mark-ups is displayed in MAINTENANCE under CUP in the STATISTICS menu.

B - Beverage *(X):

With this function the CUP key becomes a beverage key just like all the others. The operator can program the product in exactly the same way as a normal beverage. The CUP key is linked to beverage *(X). The default setting for that beverage is the cup only.

C - "Preselection *(Y)":

by pressing this key, the vending machine displays the preselection message ("Preselection Y" as default) and makes another group of beverages available extending the beverages (or recipes) that the vending machine can dispense to a total of 50 (38 Cristallo 400).

D - Disabled:

Pressing the key has no effect.

Important

The cup counter is updated for any single cup dispensed for whatever reason.

- Preselection key ("CM")

The functions associated with the preselection key can be selected from the following:

	CRISTALLO 600	CRISTALLO 400
A. *(YY)	Preselection 19-34	Preselection 15-26
B. *(XX)	Beverage 17	Beverage 13
C.	Disabled	Disabled

A - Preselection *(YY):

by pressing this key the vending machine displays the preselection message ("PRESELECTION YY" by default) and makes another group of beverages available *(YY).

Important

With this configuration it is necessary to set the new beverage/recipe group available (see the BEVERAGE BREWING menu).

B - Beverage *(XX):

by pressing this key the beverage/recipe 14 will be brewed *(XX).

C - Disabled:

pressing the key has no effect.

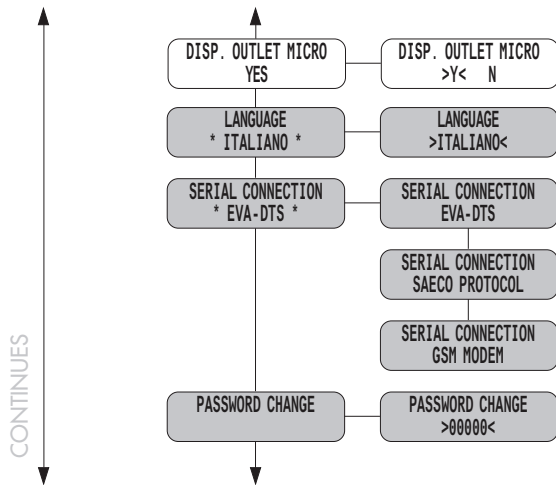

- Dispensing outlet microswitch

It enables/disables checking if the dispensing outlet door has been opened (7 - Fig. 1).

By setting YES (default value), the dispenser will check, after each brewing, that the dispensing outlet door has been opened, before allowing another beverage to be dispensed.

By setting NO, no check will be performed.



Important

The VM operates with the dispensing outlet door always open if:

- 1- "DISPENSING OUTLET MICRO" is set to NO
- 2- the dispensing outlet microswitch wiring is short-circuited

- Language ("CM")

Enables selection of the language to be used by the vending machine. Languages available: Italian, English, French, German, Spanish, Portuguese and Dutch.

- Serial Connection ("CM")

Enables selection of the intended use of the serial port on the CPU card.

Options available:

1- Saeco Protocol: The serial port is used to interact with the PC through the Saeco protocol (an optional adapter is needed for PC connection).

2- EVA-DTS: the serial port is used to send the audit data of the VMC by RS232 or infrared.

The following information is transferred:

ID1 = SAE+ VMC code, VMC model name (= COMBI), software version

ID4 = decimal point position and country code

EA3 = total number of readings, date and time of current reading, terminal identifier, date and time of last reading

LA1 = price list number, product number, product price, number of sales since last reset, number of sales since initialisation

Note: **LA1** is entered for each price list and each product price list 0 = standard prices
price list 1 = differentiated 1
price list 2 = differentiated 2
price list 3 = card
price list 4 = free
price list 5 = test

VA1 = number of dispensed products paid since initialisation, value of dispensed products paid since reset, number of dispensed products paid since reset

CA3 = Total value of coins + banknotes since reset, Value of banknotes collected since reset

CA4 = Value of change given since reset

CA8 = Overpay value since reset

CA14 = Banknote value, number of banknotes collected since reset

Note: **CA14** is entered for each banknote

DA2 = number of sales by card since initialisation, value of sales by card since reset, number of sales by card since reset, total sold in cups

DA3 = CARD IN since reset, discounts/increases

DA4 = CARD OUT since reset, value of card increases since reset

DA5 = value of card discounts since reset

Please see relevant accessory instructions for further details.

CONTINUA

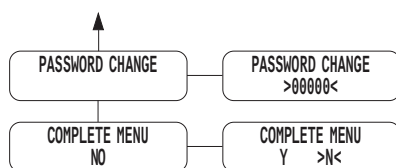

- Password change ("CM")

Enables setting of a password or modification of the current one.

The password consists of a number between 0001 and 65536. The 0000 value (default value) means no password.

To set the password, press UP and DOWN keys and confirm with the ENTER key.



Recommended solutions

To speed up entry of the password digits, the beverage keys (1, 2, 3, 7, 8, 9, Fig. 40) are linked to the following values:

Key	Value
1	+10
7	-10
2	+100
8	-100
3	+1000
9	-1000

Example: to set the value 2313 it is necessary to press:

- beverage key 2, 3 times;
- beverage key 3, twice;
- beverage key 1, once;
- UP key, 3 times;
- press ENTER key to confirm.

- Complete menu

Enables selection of whether the entries of the programming menu should be shown fully or only partially.

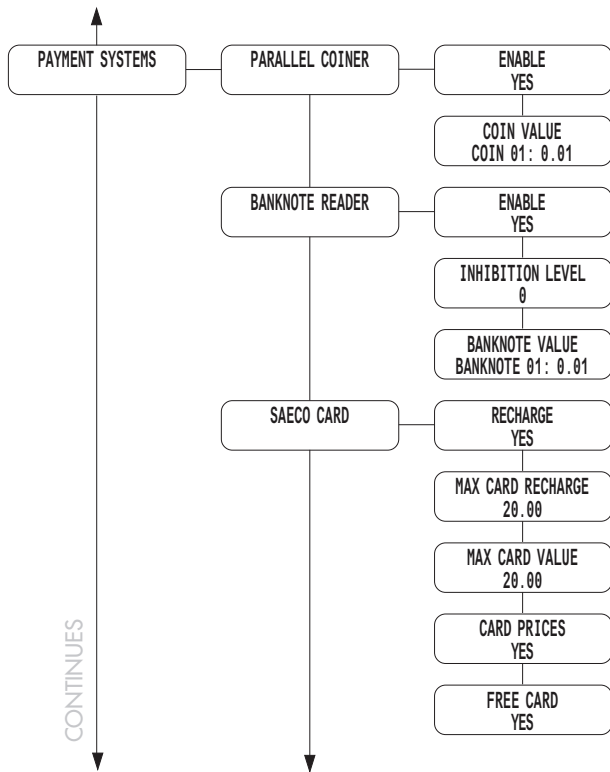

PAYMENT SYSTEMS

The entries of the PAYMENT SYSTEMS are:

- Parallel coiner

Allows enabling of the parameters of the parallel coiner, the mechanical coiner, the cancelling machine and the choice of values to be assigned to the single money channels.
Entry description:

- **Enable:** By setting “Y”, the parallel coiner, the mechanical coiner and the cancelling machine control are enabled. By setting “N”, a parallel coiner which may be connected to the vending machine is always disabled.
- **Coin Value:** Enables setting of the value of the coins transferred to the vending machine from the parallel coiner, the mechanical coiner and the cancelling machine.
The following table shows the channel/payment system combinations.

Channel	Payment system
1	Parallel coiner
2	Parallel coiner
3	Parallel coiner
4	Parallel coiner
5	Parallel coiner
6	Parallel coiner / mechanical coiner
7	Cancelling machine / mechanical coiner

- Banknote Reader

It enables the parameters of the parallel banknote validator and the choice of values to be assigned to single banknote channels.
Entry description:

- **Enable:** By setting “Y”, the management of the parallel reader is enabled. By setting “N”, a parallel reader which may be connected to the vending machine is always disabled.
- **Inhibition Level:** Enables setting of the active level of the banknote reader inhibition signal.
- **Banknote Value:** Enables setting of the value of banknotes transferred to the vending machine from the parallel reader.

- Saeco Card

The Saeco card module (automatically detected by the V.M.) adds the following entries to the PAYMENT SYSTEM programming menu.
Entry description:

- **Recharge:** Allows disabling or enabling of any Saeco card recharging operation. By setting RECHARGE = NO the vending machine will only deduct the cost from Saeco cards.
- **Max card recharge:** Enables setting of the maximum credit level, beyond which all recharge operations (if enabled) are ineffective. By setting MAX RECHARGE = 20.00, the credit on the vending machine will be transferred to the card if the sum does not exceed 20.00.
- **Max card value:** Enables setting of the maximum credit level, beyond which the card is rejected by the system. By setting Max card value = 25.00, the vending machine will reject all cards with a credit which exceeds this amount. If this card is detected, the display will not show the credit but a “ _____ ” message will be displayed and no sale will be carried out.
- **Card prices:** Enables application of differentiated prices if the card is used for payment.
By setting CARD PRICES = YES a new menu entry will appear in PRICE MANAGEMENT, enabling setting of the price level to be applied to the product (beverage or snack) if payment is made by card.
- **Free Card:** Allows enabling or disabling of the use of free service cards. By setting FREE CARD = NO, free service cards will not be accepted by the vending machine.

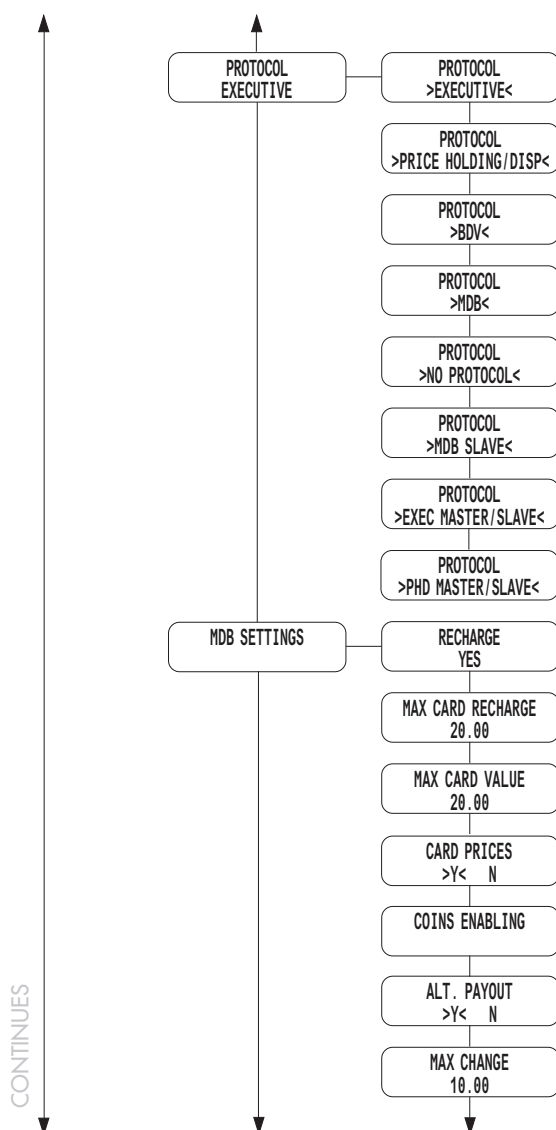

- Protocol

Enables selection of the protocol used by the vending machine to dialogue with the payment system installed on it:

- EXECUTIVE protocol;
- PRICE HOLDING/DISP Protocol;
- BDV Protocol;
- MBD Protocol;
- NO PROTOCOL (no serial protocol);
- MDB SLAVE (the vending machine operates as slave to another machine);
- Master/Slave executive (the vending machine operates as master for another vending machine);
- PHD Master /Slave (the vending machine operates as master for another vending machine that works with the PRICE HOLDING/DISP protocol);

The "NO PROTOCOL" setting will be used when a payment system operating with one of the protocols provided by the other settings "EXECUTIVE", "PRICE HOLDING", "BDV", "MDB" "MDB SLAVE" or "EXEC MASTER/SLAVE" is not installed on the VM.

This setting is necessary since the VM continuously checks for dialogue with the provided payment system. If the VM detects no dialogue, it signals this fault on the display through the message "NO LINK". This signal cannot be considered an error condition.

- MDB settings

Enables access to particular functions of the MDB protocol.

- **Recharge:** Allows disabling or enabling of any Saeco card recharge operation.

By setting RECHARGE = NO the vending machine will only deduct the cost from MDB cards.

- **Max card recharge:** Enables setting of the maximum credit level, beyond which all recharge operations (if enabled) are ineffective.

By setting MAX RECHARGE = 20.00, the credit on the vending machine will be transferred to the card if the sum does not exceed 20.00.

- **Max card value:** Enables setting of the maximum credit level, beyond which the card is rejected by the system.

By setting MAX CARD VALUE = 25.00, the vending machine will reject all cards with a credit which exceeds this amount. If this card is detected, the display will not show the credit but a "—" message will be displayed and no sale will be carried out.

- **Card prices:** This function enables application of differentiated prices if the card is used for payment.

By setting CARD PRICES = YES a new menu entry will appear in the PRICE MANAGEMENT, which will enable to set the price level to be applied to the product (beverage or snack) if payment is made by MDB cards.

- **Coins enabling:** Enables selection of which coins will be accepted by the change-giving coiner. By setting "Y" a specific coin will be accepted. On the contrary, the "N" setting prevents the change-giving coiner from accepting a particular coin. Coins beneath the vending machine scale factor are always disabled and display the "N" setting.

- **Alt. payout:** It enables/disables use of Alternative Payout for the level 3 MDB change-giver.

By setting "Yes" the change-giver is called on to dispense change.

Change is limited to 255 times the scaling factor (typically

- 12.75 for the Euro area - with scaling factor of 5).

By setting "No" change is given by exploiting the machine's algorithm.

Max. change is 60000 units (typically • 600 for the Euro area).

- **Max change:** Enables setting of the maximum amount of change which can be dispensed by the change-giving coiner. Default = 10.00.

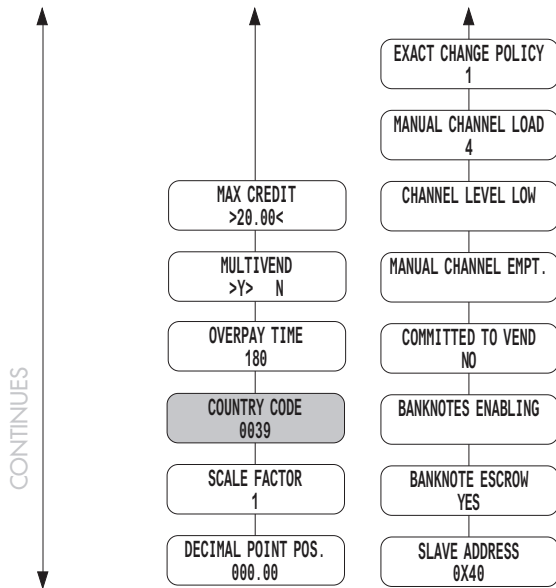

• **Exact change policy:** In MDB change-giving coiners, the condition of no change available can be selected within the following table:

Key:

- L = channel with the lowest coin value below the minimum level
- M = channel with the medium-low coin value below the minimum level
- HL = channel with the medium-high coin value below the minimum level
- HH = channel with the highest coin value below the minimum level

No.	Description
0	L or M or HL or HH
1	L or M
2	HL or HH
3	L or HH
4	L
5	M
6	HL
7	L and HH
8	HL and HH
9	L and M
10	L and M and HL and HH
11	L and HL or L and HH
12	L or HL and HH
13	HH
14	L and M and HL
15	Never (change always available)

Note

Even if the no change available message is displayed, the vending machine continues to give change as long as coins are present in the channels. The minimum level (same for all channels) can be set on a special menu item.

• **Channel level low:** Enables setting of the minimum number of coins in the channels. Default = 4.

• **Manual channel load:** Allows the change-giving coiner channels to be filled manually. Press Esc to exit the channel loading mode.

• **Manual channel empt.:** Allows the change-giving coiner channels to be emptied by pressing the beverage selection keys.

• **Committed to vend:** By setting "N", the credit inserted can be returned even if no sale has been made. This function may be useful, for example, for changing banknotes into coins. By setting "Y", the credit inserted can be returned as change only after the sale has been completed. Default = YES.

• **Banknotes enabling:** Enables selection of which banknotes will be accepted by the MDB banknote reader. A specific banknote is enabled for acceptance by setting "Y". On the contrary, the "N" setting prevents the banknote reader from accepting a specific banknote. Default = All enabled.

• **Banknote escrow:** By setting "Y", an inserted banknote is stored in the escrow position by the banknote reader (if supported); this function is supported by the banknote reader. In this way, if the sale fails or the card system fails to charge, the banknote will be returned. By setting "N", any inserted banknote goes to the banknote reader's stacker, so that the banknotes cannot be returned. Default = No.

• **Slave Address:** When the vending machine is in Master mode, this menu enables setting of the address of any slave connected vending machine. If the vending machine is in Slave mode, it enables setting of its address. Possible addresses are 0x40, 0x48 and 0x50. Default = 0x40.

- **Max credit**

This allows the user to set the maximum credit which can be accepted by the vending machine. Once this limit has been reached, the payment systems are disabled so that no more credit can be accepted. Default = 20.00.

- **Multivend**

Enables the user to use any residual credit to purchase other beverages. By setting "N" (no), the residual credit will be collected by the vending machine.

- **Overpay Time**

It establishes the maximum time (expressed in seconds) beyond which the vending machine collects the displayed residual credit. The time is adjustable at intervals of 10 seconds. By setting "000" the function is disabled.

- **Country Code ("CM")**

Enables to set the country code, which corresponds to the international dialling code (E.g. ITALY = 0039).

- **Scale factor**

Enables setting of the number of fixed zeros of the credit.

- **Decimal point posit.**

Enables setting of the position of the decimal point of the credit.

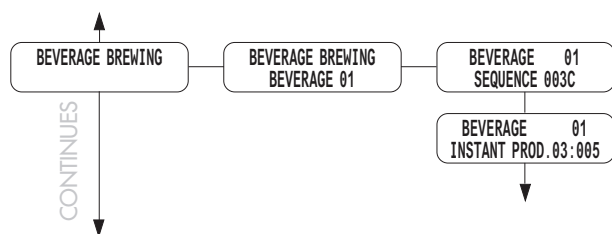

BEVERAGE BREWING (CRISTALLO 600)

The vending machine can brew 18 beverages in direct mode, or up to 50 beverages, 32 of which by means of the preselection. Each beverage can be prepared using coffee beans and/or instant products. The technician can select the desired products for the recipe (max 4) and order of use. Each component is identified by a number or a digit (Fig. 60).

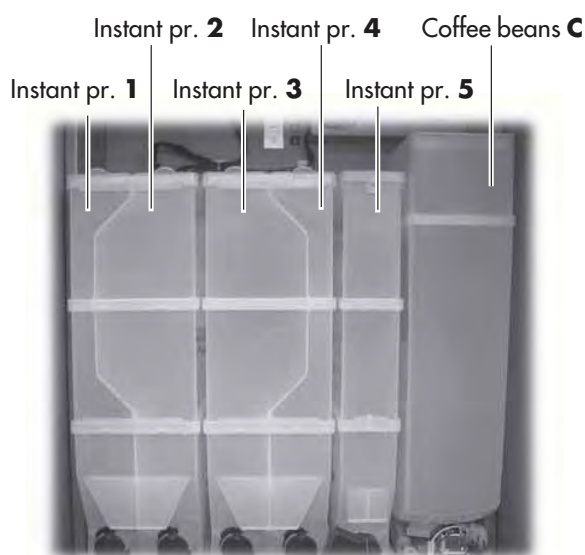
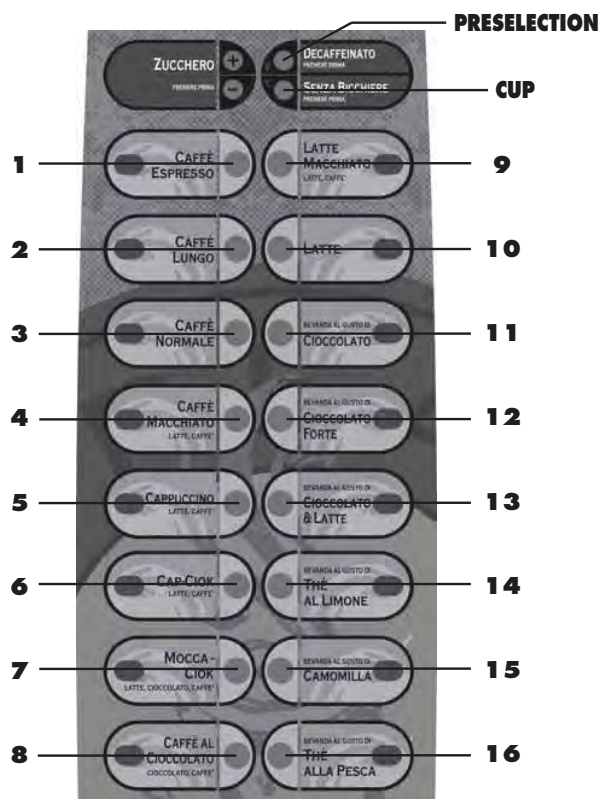

Fig. 60

The beverages are linked to the keypad keys as follows:

KEY	press KEY	press PRESEL+KEY	press CUP+KEY
1	Beverage 1	Beverage 19	Beverage 35
2	Beverage 2	Beverage 20	Beverage 36
3	Beverage 3	Beverage 21	Beverage 37
4	Beverage 4	Beverage 22	Beverage 38
5	Beverage 5	Beverage 23	Beverage 39
6	Beverage 6	Beverage 24	Beverage 40
7	Beverage 7	Beverage 25	Beverage 41
8	Beverage 8	Beverage 26	Beverage 42
9	Beverage 9	Beverage 27	Beverage 43
10	Beverage 10	Beverage 28	Beverage 44
11	Beverage 11	Beverage 29	Beverage 45
12	Beverage 12	Beverage 30	Beverage 46
13	Beverage 13	Beverage 31	Beverage 47
14	Beverage 14	Beverage 32	Beverage 48
15	Beverage 15	Beverage 33	Beverage 49
16	Beverage 16	Beverage 34	Beverage 50
PRESELECTION	Beverage 17		
CUP	Beverage 18		



• Sequence

This is the order in which the products making up the beverage are brewed.

"0" does not correspond to any product. Thus, the combination of digits "C300" or "C030" or "OC30", always means that product 3 and coffee beans will be brewed.

The settings of products making up the beverage will be requested according to the sequence.

• Instant product:

This defines the quantity of instant product to be brewed. Example: "005" quantity indicates that the motor of the instant product 3 will be activated for 5 tenths of a second.

The quantity of instant product is adjustable from "0" to "250" in steps of 1. Brewing of the instant product does not occur when the parameter is set at "0000" (in this case water is brewed).

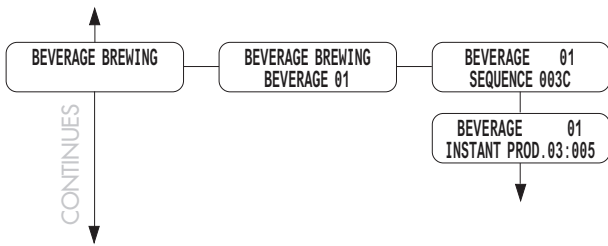

BEVERAGE BREWING (CRISTALLO 400)

The vending machine can brew 14 beverages in direct mode, or up to 38 beverages, 24 of which by means of the preselection. Each beverage can be prepared using coffee beans and/or instant products. The technician can select the desired products for the recipe (max 4) and order of use. Each component is identified by a number or a digit (Fig. 60).

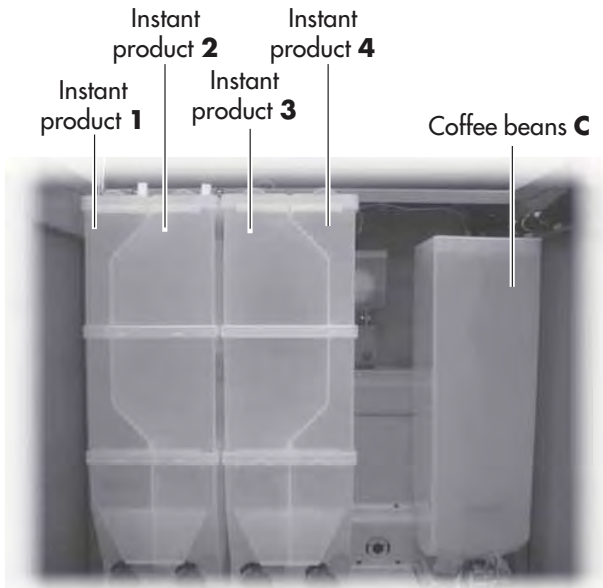
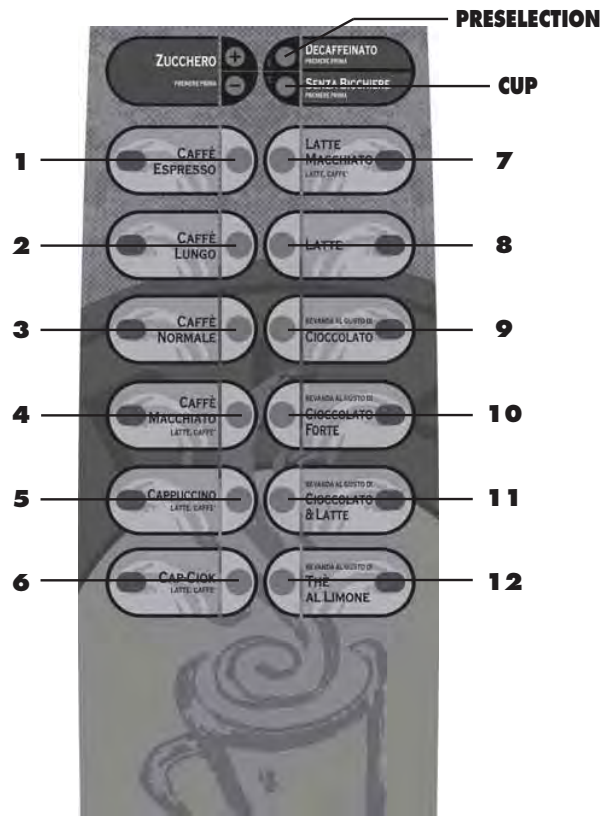

Fig. 60

The beverages are linked to the keypad keys as follows:

KEY	press KEY	press PRESEL+KEY	press CUP+KEY
1	Beverage 1	Beverage 15	Beverage 27
2	Beverage 2	Beverage 16	Beverage 28
3	Beverage 3	Beverage 17	Beverage 29
4	Beverage 4	Beverage 18	Beverage 30
5	Beverage 5	Beverage 19	Beverage 31
6	Beverage 6	Beverage 20	Beverage 32
7	Beverage 7	Beverage 21	Beverage 33
8	Beverage 8	Beverage 22	Beverage 34
9	Beverage 9	Beverage 23	Beverage 35
10	Beverage 10	Beverage 24	Beverage 36
11	Beverage 11	Beverage 25	Beverage 37
12	Beverage 12	Beverage 26	Beverage 38
PRESELECTION	Beverage 13		
CUP	Beverage 14		



• **Sequence**

This is the order in which the products making up the beverage are brewed.

"0" does not correspond to any product. Thus, the combination of digits "C300" or "C030" or "OC30", always means that product 3 and coffee beans will be brewed.

The settings of products making up the beverage will be requested according to the sequence.

• **Instant product**

This defines the quantity of instant product to be brewed. Example: "005" quantity indicates that the motor of the instant product 3 will be activated for 5 tenths of a second.

The quantity of instant product is adjustable from "0" to "250" in steps of 1. Brewing of the instant product does not occur when the parameter is set at "0000" (in this case water is brewed).

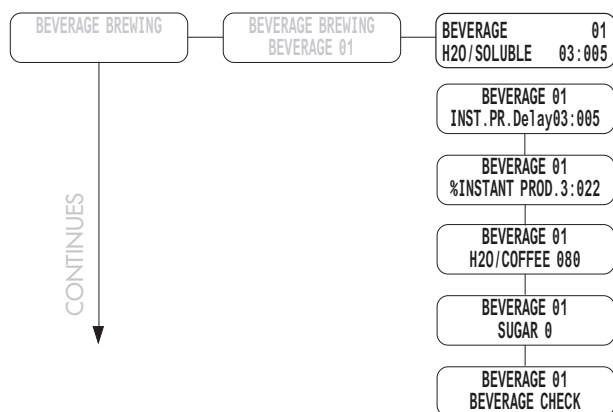

Important

If the sequence includes several instant products, the sequence "INSTANT PRODUCT - WATER - DELAY - INSTANT PRODUCTS - % OF INSTANT PRODUCT" will be shown again.

If the setting relative to the instant product ("INSTANT PRODUCT - WATER - % INSTANT PRODUCT") means that the powder dispensing lasts longer than the water dispensing, the vending machine stops powder dosing (to avoid insufficient rinsing of the mixer) and emits a beep. Check the settings again to obtain correct dispensing (powder dispensing must end a few instants before the water dispensing is complete, to allow good rinsing of the mixer).

• H2O / Soluble

It defines the amount of water to be mixed with the instant powder.

Example: "3" indicates that water will be mixed with the instant product 3. "022" indicates that 22 water units will be brewed with the instant product. The reference unit is preset by the manufacturer. The amount of water can be adjusted from "0" to "500" in steps of 2.

• Motor delay

This option enables entry of a programmable start delay on instant product motors.

• % Instant product

This defines the speed at which the instant powder and water are brewed (see chart).

Brewing speed of instant powder and hot water is adjustable from "10" to "120" in steps of 10.

By setting a value of "10", the pump works at the maximum capacity, while the instant product is brewed with impulses, at minimum capacity. Setting "100" both the instant product and water will be brewed at maximum capacity.

Setting "120" the pump works, with impulses at minimum capacity, while the instant product is brewed at maximum capacity.

• H2O / Coffee

This defines the quantity of coffee to be brewed.

Example: "38" indicates that 38 water units will be brewed. The reference unit is preset by the manufacturer. The quantity of dispensable coffee can be adjusted from "0" to "500" in steps of 2.

• Sugar

This defines the quantity of sugar to be dispensed with the beverage.

The following table shows the result of the various settings.

Settings	Sugar in beverage without preselection	Sugar in beverage with preselection
0	Without	Quantity preselected
1	1	Quantity preselected
2	2	Quantity preselected
3	3	Quantity preselected
4	4	Quantity preselected
NO	Without	Without sugar

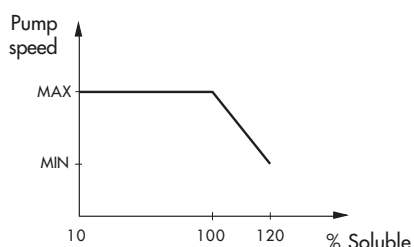
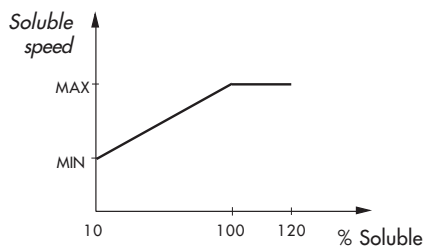

Fig. 60

• Beverage check

Enables brewing tests to be carried out on the beverage just set.

By pressing **ENTER** the message "PRESS KEY" is displayed and it is possible to choose the key to be pressed, relative to the type of brewing test:

- **A** key Full beverage;
- **B** key Beverage without cup, sugar and stirrer;
- **C** key Water only;
- **D** key Powder only.

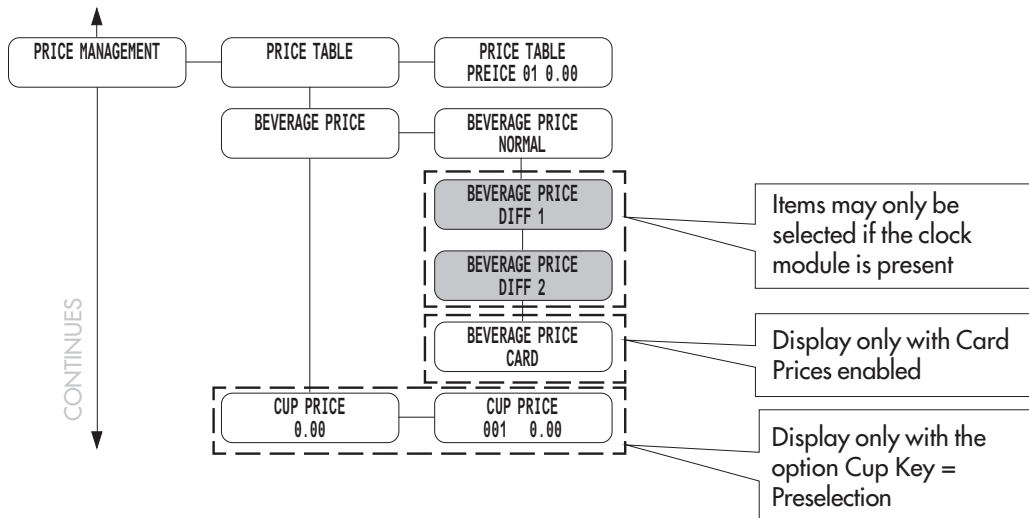

PRICE MANAGEMENT

The PRICE MANAGEMENT items are:

- **Price table**
99 price levels can be set.
- **Beverage price**
Enables association of one of the price levels set in the PRICE TABLE to each beverage.
The association can be:
 - **GLOBAL PRICE** (all beverages are given the same price level);
 - **SINGLE PRICES** (each beverage will be given a specific price level).
- **Global price setting**
By pressing the UP and DOWN keys and confirming with ENTER, it is possible to choose the price level to associate to all beverages.
- **Single price setting**
Enables selection of the price level to associate to each beverage.
Select the beverage to associate to a price using the UP and DOWN keys and confirm with ENTER, then select the price level (from 001 to 099) again with the UP and DOWN keys and confirm with ENTER.

- **Cup Price**
(Displayed only if the Cup key is set to PRESELECTION mode)
It allows a price to be assigned to the cup if cup preselection is enabled.
The VMC will calculate the cost of the dispensed product based on two components:
 - a beverage
 - a cup

The operator will therefore have to set the price for both components. The amount paid by the user for each product with cup is given by the sum of the beverage price plus the cup price.

A practical example is given below.
If:

price level 1 = 0.50
price level 2 = 0.05

	Beverage Price	Cup price	Final Cost	Increased Counters
Beverage with cup	Level 1	Level 1	0.55	Beverage counter and cup counter
Beverage without cup	Level 2	Level 2	0.50	Beverage counter

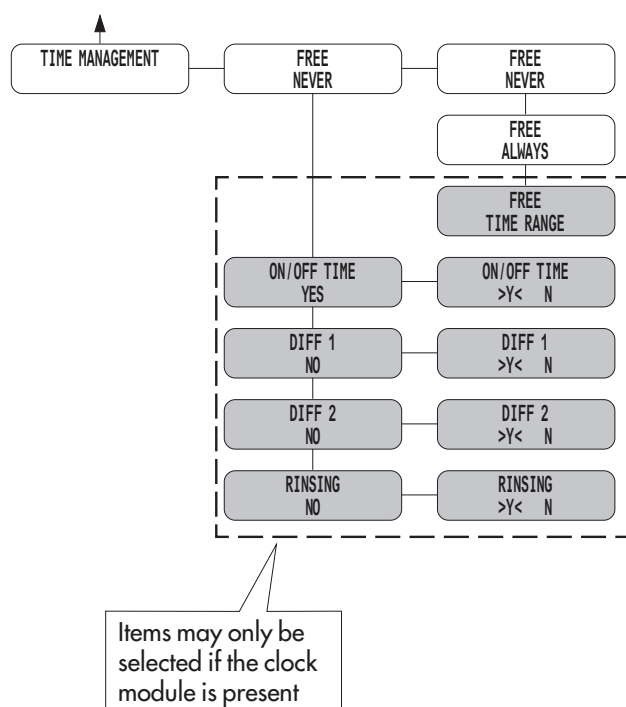

TIME MANAGEMENT

The ITEMS of the TIME MANAGEMENT menu are:

- **Free never**
Products and beverages supplied must be paid.
- **Free always**
Products and beverages supplied are free.



Important

When the Timekeeper clock module is present, it is possible to set:

- rinsing times;
- switch on/off times;
- differentiated pricing times;
- free dispensing times.

8.3 Maintenance menu

The structure of the maintenance menu is shown at 8.3.2. All entries present in the maintenance menu are described at 8.3.3.

8.3.1 Entering the maintenance menu



Open the upper door, disable the safety device (see 3.4) and press the **P2** key (Fig. 61) to enter the maintenance menu.

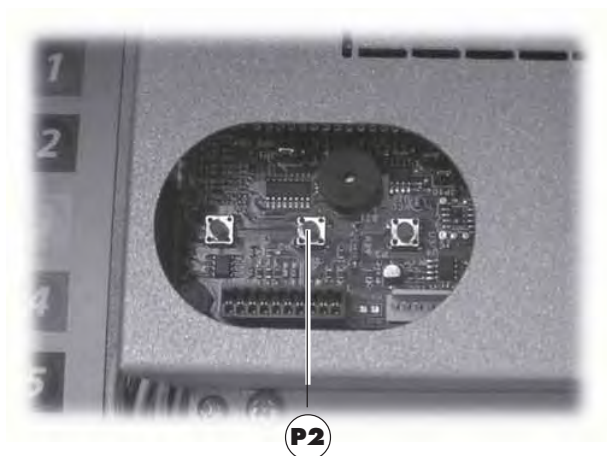
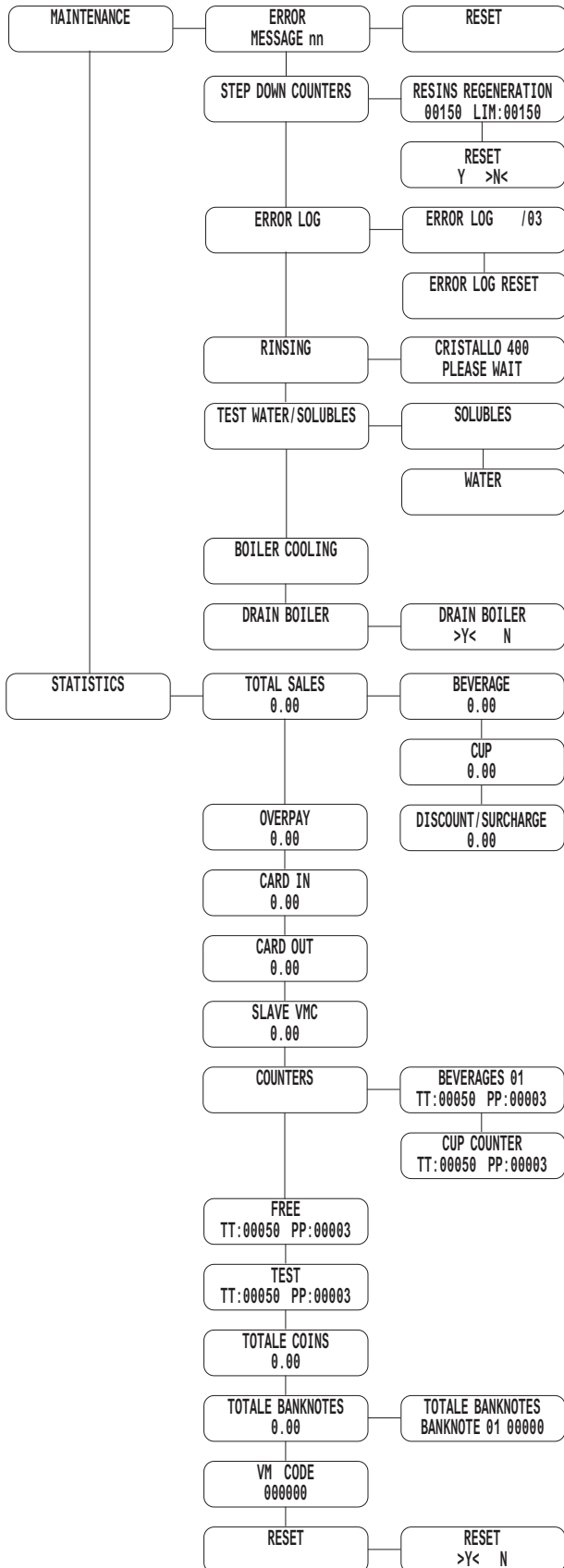

Fig. 61

To exit the maintenance menu and return to the standard operation of the vending machine:

- Press the **P2** key again;
- remove the key from the safety switch in order to turn off the vending machine;
- close the door and wait for the self-configuration process to end.

8.3.2 Structure of the maintenance menu



8.3.3 Description of messages in the maintenance menu

MAINTENANCE

This function enables the display and cancellation of any errors that may be present. It is also possible to carry out maintenance on the vending machine.

The errors can be reset through the maintenance menu or using the Automatic Error Reset mode.

The Automatic Error Reset mode, designed to be used by non-qualified technical personnel, can be activated without entering the programming / maintenance menu and attempts to remove automatically any (non-critical) error conditions that may occur to the V.M.

This mode does not eliminate all error conditions, but only those caused by operational faults.

Errors are divided into two groups (faults and failures) depending on how serious they are and how easy it is to remove the faults.

Faults include error conditions automatically recovered following removal of their cause, or conditions requiring an operator's intervention which are therefore eliminated only upon the operator's request.

Failures, on the contrary, always require technical intervention by qualified personnel (ved. tab. par. 11.2).



Recommended solutions

In maintenance mode it is possible to:

- start the gear motor of the brew group by pressing beverage key **1** (Fig. 40);
- start the nozzle arm by pressing beverage key **2** (Fig. 40);
- have the mixer rinsed by pressing beverage key **3** (Fig. 40);
- display total and partial counters for 5 seconds by pressing beverage key **4** (Fig. 40).
- start the cup release by pressing beverage key **6** (Fig. 40);
- reset errors by pressing beverage key **12** (Fig. 40).

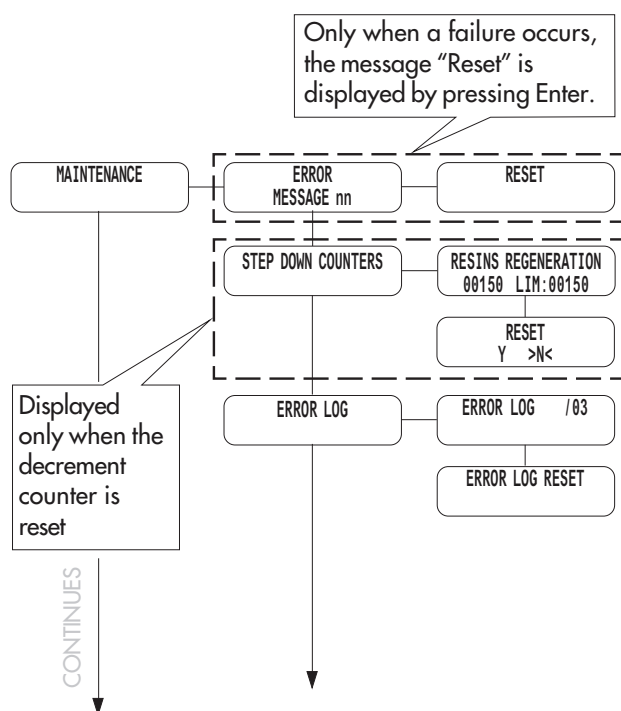

- Error / Message nn

This describes the current error (check the cause in section 12 - Error messages). If no error is present, this message is not displayed.

After checking the error cause, press the ENTER key to reset the vending machine (see section 12 for the complete list of errors).

- Step down counters

By pressing Enter you may see which operation is needed. By pressing Enter again it is possible to reset the message that is bringing the quantity of dispensable water back to the limit value.

The message does not block the machine. The vending machine continues working normally even when the decrement counter is reset.

- Automatic Error Reset

Simplified error reset mode (for use by non-qualified technical personnel); when enabled, attempts to remove any non-critical error condition for the VM operation.

Starting the error reset procedure

The error-reset procedure is enabled by pressing both the P1 "Programming" and P2 "Maintenance" keys simultaneously for at least 5 seconds (see Fig. 40, ref. 1 and 2).

A beep signals the start of the procedure.

Reset procedure when no errors are present

If no failure is present, the message "Ok - 0/0" is displayed. The user can go back to the standard mode by pressing the ENTER key.

This way, a quick system check-up by the operator is also ensured.

Reset procedure when errors are present

If errors are present the procedure consists of two phases:

1. Error list;
2. Error removal (removal attempt).

1- Error list

The VM displays a list of errors detected. The first line on the display indicates the total number of errors "XX ERRORS".

The second line on display shows the list and descriptions of errors on one or more screen pages. This list shows the current active error or fault messages of the vending machine: Each message is displayed on a screen with the error description, e.g.: "NO WATER 01".

The user goes to the following screen page by pressing the ENTER key.

The error removal stage is accessed by pressing ENTER again after the last screen page.

2 - Error removal (removal attempt)

The VM attempts to remove the errors automatically in sequential order. During this phase the error subject to the reset procedure is displayed.

A "status bar" is shown on the second line of the display: The bar elements are "dots" ("."). At the end of each attempt the display shows the message Ok/Fail and then proceeds with the following step.

If, at the end of the sequence all the errors have been removed, the reset is considered successful; otherwise (one or more failures are still present) the reset is considered failed.

Reset successful

The VM shows the message "Ok - N/N" and emits a long single beep. N indicates the number of errors removed. The vending machine is reset by pressing the ENTER key.

Reset failed

If, at the end of this procedure, at least one error condition remains unchanged, the display will show the message "Fail X/N" where X is the number of errors that could not be removed and N the total number of errors detected.

The message is accompanied by a few short beeps. The vending machine is reset by pressing the ENTER key.

- Error recording

The VM records significant events that occurred to VMC in the internal Eeprom (e.g. errors, Warning signals etc.).

Recording takes place when the error condition is detected and consists of saving the following information:

- 1- error code (or warning code) occurred;
- 2- location of signal source (e.g., which spiral motor, if the error is due to a spiral motor, or which coffee or instant product);
- 3- day, month, hour and minute of error detection (this information is available only if the VM is equipped with a timekeeper).

The recordings are included in a list which may contain up to 50 elements; when this limit is exceeded the information is input again starting from position 1 (previous information will be lost).

Note

All errors or faults are stored, except when blocks occur (coffee, instant product, beverage, water).

Display:

```
ERROR LOG   ii/NN
Exx aabb ddmmm hh:mm
```

Format of warning error description recorded in LOG:

```
Exx   WHAT ==> xx code error/warning alarm
aabb  WHERE==> if Myy = spiral motor yy
aabb  WHERE==> if Syy = yy instant product dispensing
aabb  WHERE==> if Lyy = yy instant product rinsing
aabb  WHERE==> if C — = coffee brewing
aabb  WHERE==> if aabb = hexadecimal codes
ddmmm WHEN==> day in figures, month in string (3
                letters)
hh:mm WHEN==> hour:minutes
ii     error index in LOG
NN     number of errors in LOG
```

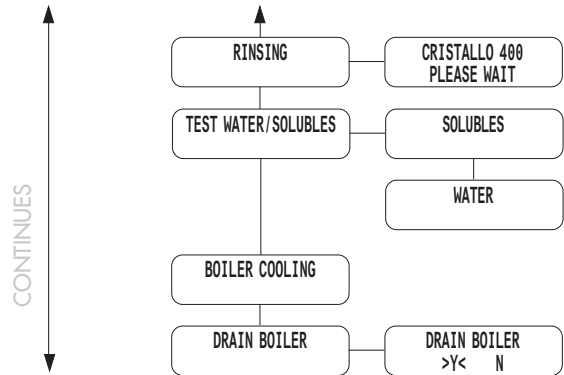

- Rinsing

Enables rinsing of the instant product brewing circuits. By pressing the ENTER key the automatic cycle starts, thus activating each instant product circuit in sequence.



Recommended solutions

To rinse the circuit of a single instant product it is necessary to keep the beverage keys pressed:

- Beverage key 2: instant 1 rinsing
- Beverage key 3: instant 2 rinsing
- Beverage key 4: instant 3 rinsing

- Test Water/Instant product

Instant product check: It enables the selection of one of the instant product dispensing motors available on the vending machine, and to actuate it for 5 seconds, so that its capacity can be checked.

Water check: It enables the selection of one of the solenoid valves available on the vending machine, and to actuate it for 10 seconds, so that its capacity can be checked.

- Boiler Cooling

Allows quick cooling of the boiler.

By selecting the item " BOILER COOLING " the VM dispenses water until the temperature detected by the sensor placed on the boiler has fallen below 50°C.

A coloured bar on the display indicates the current temperature of the boiler. When the bar disappears the temperature detected is less than 50° and the cooling down operation is completed; the VMC must be turned off.

- Boiler emptying

It enables start-up of the automatic discharge cycle of the boiler.

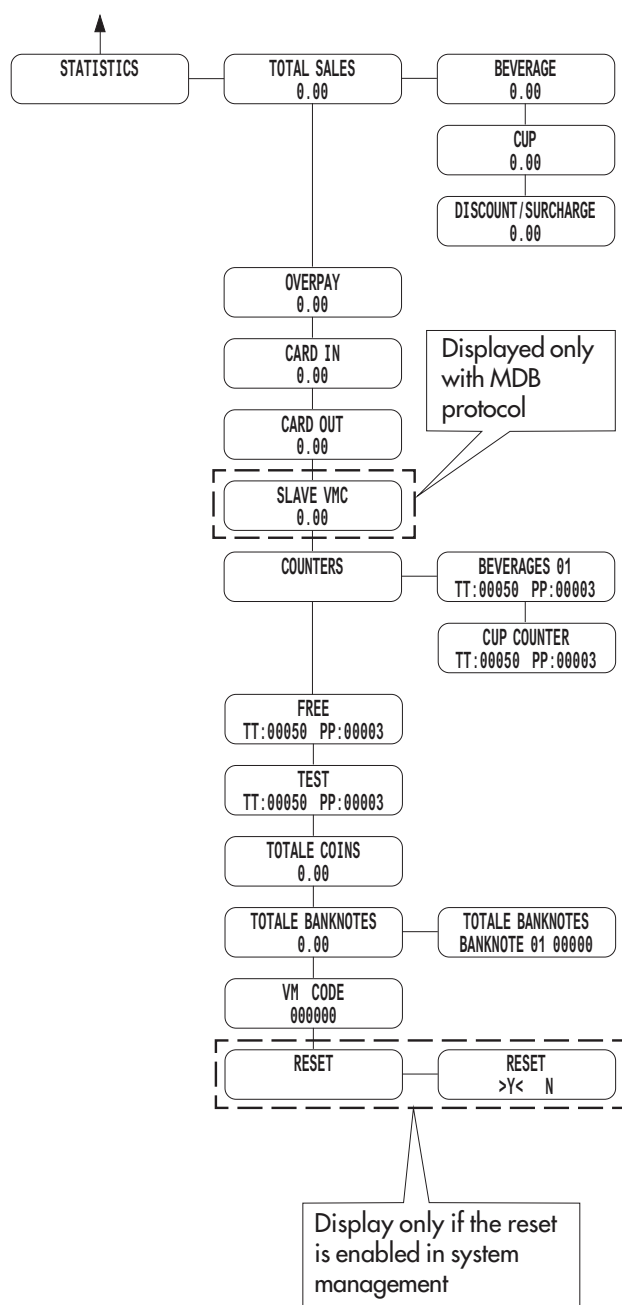

STATISTICS

- **Total sales**
The total revenue from the sales of all selections and beverages is displayed.
By pressing [ENTER] it is possible to obtain detailed information of this revenue for:
 - beverages (further divided according to price level, if required)
 - cups sold
 - discounts and increases made
- **Overpay**
The amount of credit collected when the OVERPAY time has elapsed is displayed.
- **Card-In**
The amount of credit collected from cards is displayed.
- **Card-Out**
The amount of credit charged on cards is displayed.
- **VMC Slave**
The amount of sales made by the Slave is displayed.
- **Counters**
The presence of the Timekeeper in this menu allows the extension of the quantity of information displayed.
It is possible to display the total and partial number of beverages divided into price bands.
- **Free**
The total number of free beverages dispensed is displayed.
- **Test**
The total number of test beverages dispensed is displayed.
- **Total coins**
The total value of the coins inserted is displayed.
- **Total banknotes**
The total value of the banknotes inserted is displayed.
By pressing [ENTER] it is possible to display the number of banknotes inserted according to their denomination.
- **VM Code**
Assigned by the manufacturer.

9 OPERATION AND USE

9.1 Beverage selection



The **Cristallo 600** vending machine can dispense 50 beverages.

The **Cristallo 400** vending machine can dispense 38 beverages.

The following are the conditions necessary to select a beverage:

- the vending machine has reached the set temperature after the start-up. Otherwise, once a beverage key is pressed, the display shows the message "HEATING";
- the credit available is sufficient or the vending machine has been set in free mode. If this is not the case, the display shows the message "INSERT XXX";
- there is no error condition that prevents the dispensing of beverages. If this is not the case, the display shows the error message "OS BEVERAGES XXX" alternated with "NOT AVAILABLE";
- the beverage selected is enabled. If this is not the case, the message "NOT AVAILABLE" will be displayed;
- there is no block condition for the beverage selected. If this is not the case, the message "BEVERAGE XXX" alternated with "NOT AVAILABLE" is displayed before the key is pressed. After the key is pressed, the display shows the message "NOT AVAILABLE";
- the dispensing outlet door is closed. If this is not the case, the display shows the message "CLOSE SERVICE DOOR".



Important

The brewing cycle cannot be interrupted by the dispensing outlet door open, until cup, sugar and stirrer loading is complete.

If the door is opened accidentally, it should be closed and the beverage brewing will continue automatically.

During the brewing of a beverage:

- payment systems are disabled;
- the first line on the display shows the programmable dispensing message (default message is: "WAIT FOR PRODUCT").

Beverage selection

If the vending machine is not set to dispense free beverages, insert the credit required.

Press the key corresponding to the beverage required.

When the beverage is dispensed, the message "REMOVE CUP" is displayed. Take the beverage out of the dispensing outlet.

After closing the door the display will show the message "THANK YOU" and after a few seconds "CRISTALLO 400" (the vending machine is awaiting selection).



Warning

To avoid scalding, wait for the end of brewing signal (the message "REMOVE CUP" will appear on the display) before placing your hand in the dispensing outlet.

Do not open the dispensing outlet door while the vending machine is brewing.

In case of failures or product missing during the brewing phase, a message indicating the cause of this stop will appear on the display.

Messages and special warnings are listed in section 11.

10 CLEANING AND MAINTENANCE



Warning

Unplug the power cord before performing any cleaning and/or maintenance operation.

It is prohibited to perform cleaning or maintenance operations on the internal components of the vending machine with the safety microswitch disabling key inserted.

The Manufacturer declines any liability for any damage or malfunctioning caused by incorrect or poor maintenance.



Important

During the loading operations do not stress any of the live electrical parts and do not clean them with damp cloths.

10.1 General notes for correct operation



The vending machine and its non-removable components must be cleaned using non-abrasive sponges or damp cloths.

Do not direct water jets on the components and/or on the vending machine.

Check for correct brewing of beverages and adjust the grinding when necessary.

To guarantee the correct operation of the vending machine it is recommended to conform to the instructions and times indicated in the MAINTENANCE SCHEDULE (see 10.2.1).

10.2 Cleaning and scheduled maintenance



Warning

All components must be rinsed with warm water only, without using any detergent or solvent that could modify their form and operation.

Removable components cannot be rinsed in the dishwasher.

During the cleaning and maintenance operations do not stress the following electrical components: CPU card; starter port; interconnection port.

Do not clean the above mentioned electrical components using damp cloths and/or degreasing detergents. Remove dust residues with a jet of dried compressed air or using an antistatic cloth.

10.2.1 Maintenance schedule



Daily

Use a damp cloth with detergents suitable for cleaning products in contact with food:

- the display (2 - Fig. 1);
- the "instructions for use" label (6 - Fig. 1);
- the beverage dispensing outlet (7 - Fig. 1);
- the keypad (3 - Fig. 1).

Weekly

- Clean the drip tray (see 10.2.2).
- Replace the coffee grounds bag (see 10.2.3).
- Empty the fluid discharge tank and wash it (see 10.2.4).
- Clean the stirrer channel (see 10.2.12).
- Clean the coffee bean brew group and the coffee ground channel (see 10.2.5).
- Clean the mixer and dispenser of the instant products (see 10.2.6).
- Clean the dispensing outlet (see 10.2.7).

At each supply

- If necessary, clean the coffee bean, instant product and sugar containers (see 10.2.8).

Monthly

- Remove the components of the dispensing outlet and wash them carefully (see 10.2.7).
- Clean the dispensing arm (see 10.2.9).
- Clean the coffee grinder (see 10.2.10).

10.2.2 Drip tray cleaning



Remove the tray and clean it carefully (Fig. 62).

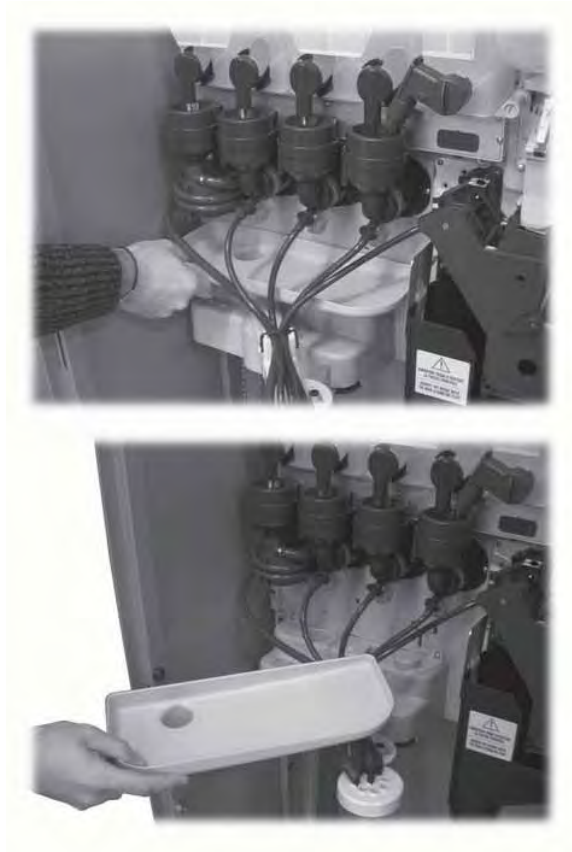

Fig. 62

10.2.3 Replacement of the coffee ground bag



Tighten the clip, extract the full bag and replace it with a new one (Fig. 63).



Fig. 63

10.2.4 Emptying the fluid discharge tank



Remove the tank from the vending machine (Fig. 64).



Fig. 64

Wash the tank, than replace it inside the machine.

10.2.5 Cleaning of the coffee brew group



Disconnect the hose from the dispensing arm (Fig. 65).

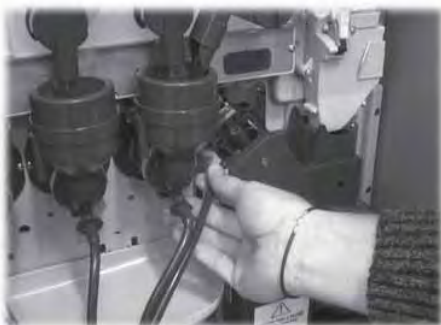

Fig. 65

Remove the brew group keeping the lever in **3** position (Fig. 66 and 67).



Fig. 66



Fig. 67

Wash the brew group with lukewarm water and clean the upper filter carefully (Fig. 68).

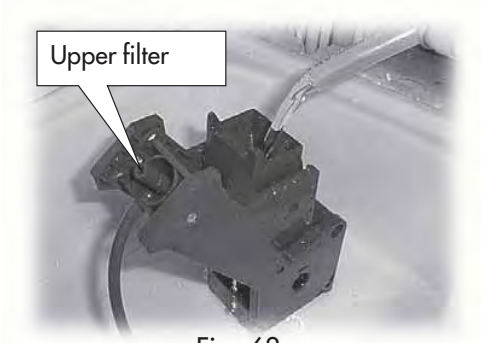

Fig. 68

Important

When inserting the brewing group, make sure that the reference arrows are aligned. If this is not the case, align them using the key provided.

Important

Before removing the coffee ground channel for cleaning, it is necessary to remove the brew group.

Lift and remove the coffee ground channel (Fig. 69) and wash it with lukewarm water.



Fig. 69

10.2.6 Cleaning the instant product dispenser and the mixer

Disconnect the dispensing hose from the nozzle and from the dispensing arm (Fig. 70).



Fig. 70

Remove the cover and the instant product funnel (Fig. 71).



Fig. 71

Remove the fan by levering carefully with a flat screwdriver (Fig. 73).

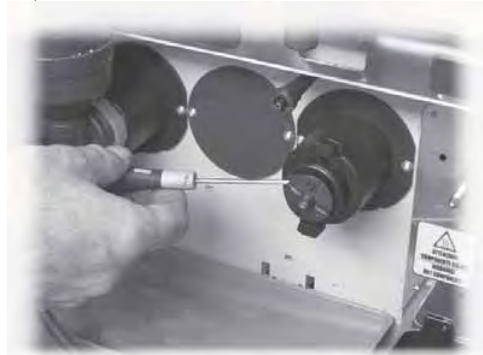

Fig. 73

Turn the blocking ring clockwise (Fig. 72) and remove the mixer body.



Fig. 72

Wash all components with lukewarm water and pay particular attention not to damage the fan. Assemble the components in reverse order and connect the dispensing hose correctly.

10.2.7 Cleaning the dispensing outlet



Operate on the dispensing outlet locking lever (Fig. 74).



Fig. 74

Remove the dispensing outlet (Fig. 75).

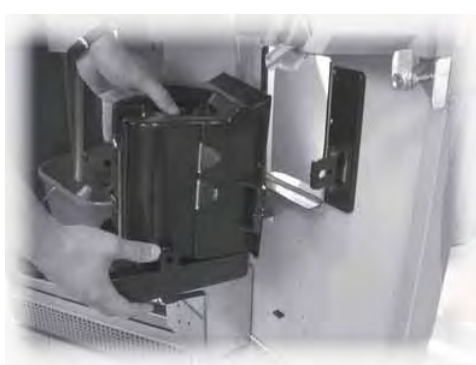

Fig. 75

Remove the lower plate from the dispensing outlet and wash it thoroughly with lukewarm water (Fig. 76).



Fig. 76

Reassemble the lower plate onto the dispensing outlet only when they are completely dry.

Assemble the components in reverse order.

10.2.8 Cleaning the containers



To clean the coffee bean hopper the following operations are necessary:

- push the moving panel inward (Fig. 77);
- dispense a few test coffee cups in order to empty the coffee grinder from coffee beans;
- lift the container up and remove the bean residues using an aspirator;
- wash the inside of the container and dry it carefully before reassembling it.



Fig. 77

The following operations are necessary to clean the instant product container:

- turn the container locking lever clockwise (Fig. 78);



Fig. 78

- remove the container (fig. 79) by pushing it towards the inside of the vending machine in order to release the lock (A), then push it upwards



Fig. 79



- wash the inside of the container and dry it carefully.
- to reassemble the container, follow the same procedure in reverse order, paying attention to insert the lock (A) into the appropriate slot.

- wash the inside of the container and dry it carefully before reassembling it.

The following operations are necessary to clean the sugar container:

- turn the container locking lever clockwise (Fig. 80);



Fig. 80

- remove the container (Fig. 81);



Fig. 81

- wash the inside of the container and dry it carefully before reassembling it;

- replace the container taking care to insert the nozzle into the coupling (Fig. 82).



Fig. 82

10.2.9 Cleaning the dispensing arm

Remove the elastic which blocks the hoses (Fig. 83).



Fig. 83

Disconnect the hoses from the dispensing arm (Fig. 84).

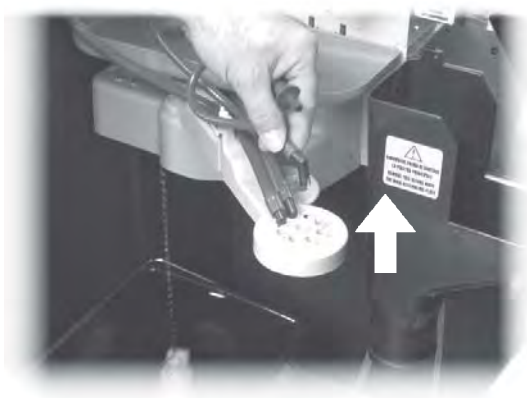

Fig. 84

push the rubber tip (Fig. 85) to release the dispensing arm.



Fig. 85

Remove the brewing unit (Fig. 86).

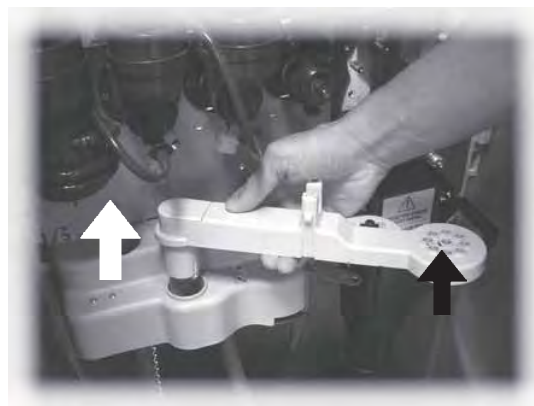

Fig. 86

Wash the components in lukewarm water and assemble in reverse order.

10.2.10 Cleaning the coffee grinder



Each month, clean the coffee grinder of any residues that might lead to deposits.

After removing the coffee bean hopper (10.2.8 - Fig. 77), clean the coffee grinder carefully with an aspirator.

10.2.11 Cleaning the sugar dispensing channel



- Unscrew the knurled pin to remove the movable sugar chute from the support (Fig. 87);



Fig. 87

- Unfasten the screw fixing the movable sugar chute to the connecting rod (Fig. 88).



Fig. 88

Wash the movable sugar chute in lukewarm water and assemble in reverse order.

10.2.12 Cleaning the stirrer channel



Remove the stirrer channel (Fig. 89).

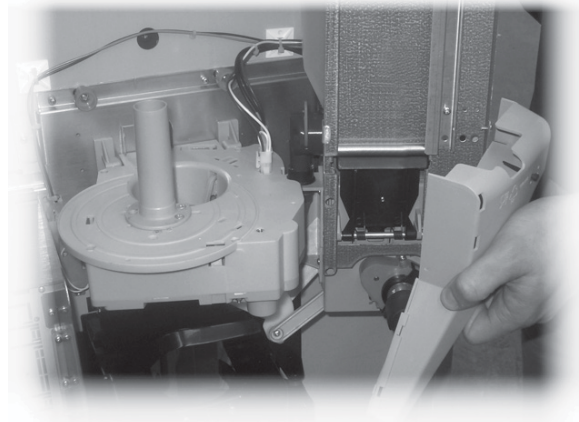
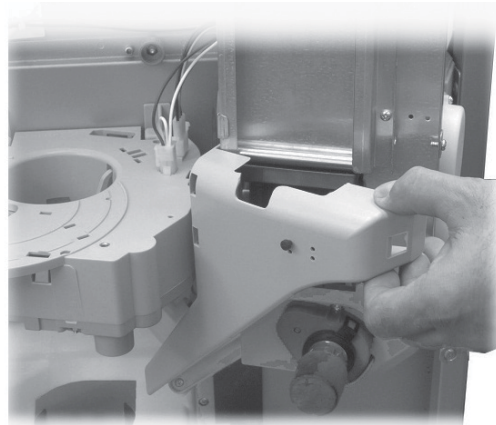

Fig. 89

Wash the stirrer channel in lukewarm water and assemble in reverse order.

10.3 Non-scheduled maintenance



The vending machine is equipped with an assembly plate containing most of the vending machine components (Coffee grinder, Gear motor, Mixer, Instant product motors, Pump, Turbine and De-humidifier).

If one of these components needs to be accessed, the instant product and coffee containers must be removed; place the cover (Fig. 90 ref. **A**) on the coffee grinder to avoid any remaining coffee spilling out, and unfasten the four fixing screws (Fig. 90 ref. **B**).

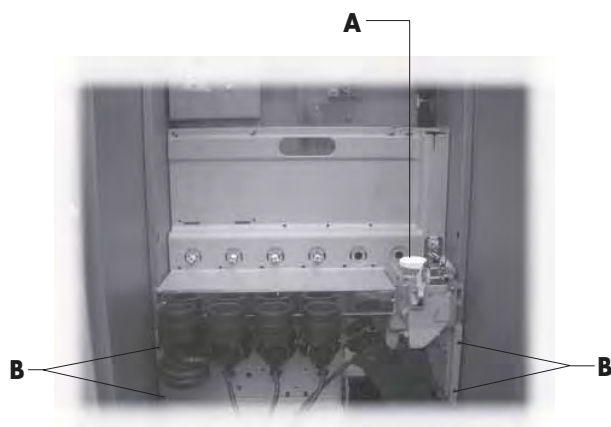

Fig. 90



Important

The boiler can be accessed without inclining the plate, by turning the two knobs fixing the support plate (Fig. 92).

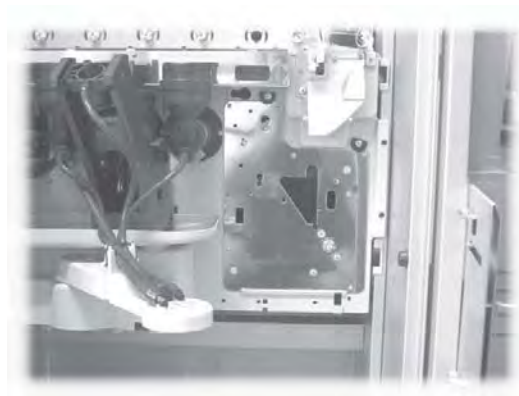

Fig. 92

Pull the plate upwards and incline it forwards (Fig. 91). It is now possible to access all the plate's mechanical components.

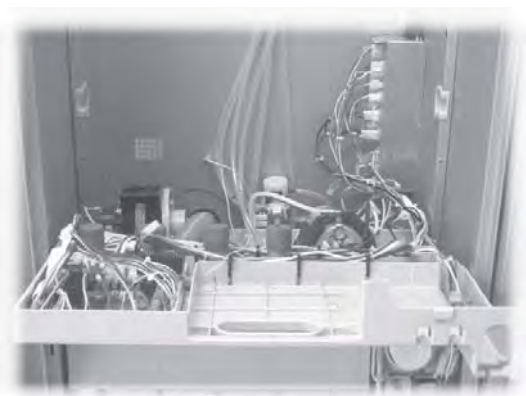

Fig. 91

10.4 Software updating



The vending machine control program is in the flash memory inside the microcontroller.

The software can be updated via an external memory.

The following is the procedure to perform the above mentioned updates.

External FLASH or EEPROM memory

The procedure is as follows:

- turn off the vending machine;
- remove the guard;
- remove the TIMEKEEPER (if any);
- insert the external memory on the 16x2 strip (Fig. 93) with **PIN 1** notch turned towards the right; Make sure all the memory pins are fully inserted, so that they fit the 16x2 strip perfectly.

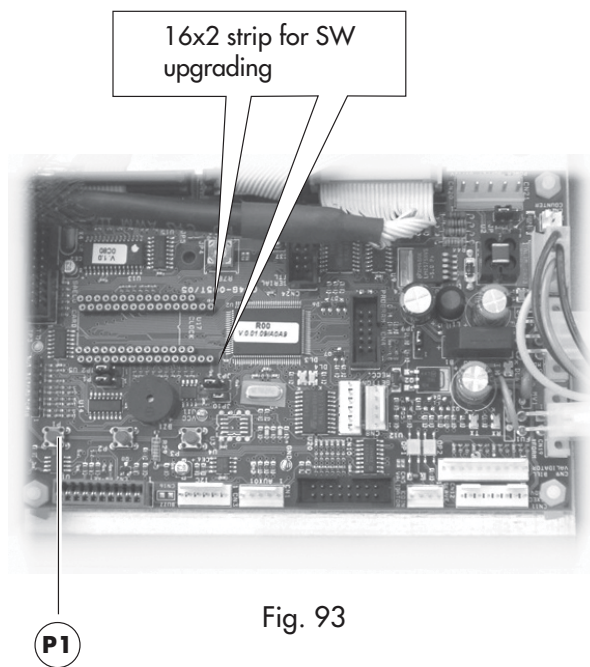

Fig. 93

- Turn on the vending machine. The vending machine checks if a suitable external memory is present. If this is the case, the following message is displayed:

PRESS P1 TO UPDATE
FROM VX.yz > TO A.bc

- the message on the second line indicates that if the program update is carried out, the current version (X.yz) will be replaced by the version in the flash memory (A.bc);
- to proceed with software upgrade the internal **P1** key (Fig. 93) of the CPU card must be pressed; any other key will abort the operation;
- the software updating requires about 30 seconds and the end of the procedure is indicated by a message on the display;

UPDATE COMPLETED

- turn off the vending machine;
- remove the external memory;
- put the TIMEKEEPER back in place if necessary;
- replace the guard.

11 DISPLAY MESSAGES

This section shows the display messages:

- during standard operation;
- in case of a fault (error messages).

11.1 Messages during operation

The table below shows a list of messages displayed during the standard operation.

Cod. errore	Messaggio	Cause	Rimedio
/	CRISTALLO 400/600	The vending machine is in stand-by.	
/	WAIT FOR PRODUCT	Product dispensing in progress.	
/	CLOSE DOOR	Dispensing outlet door open.	Close the door
/	SUGAR 1-x SUGAR 2-xx SUGAR 3-xxxxx SUGAR 4-xxxxxxx	SUGAR QUANTITY to be dispensed with the beverage.	
/	PRESELECTION xx-xx	Preselection of the second or third set of beverages activated.	
/	CAFFEE NOT AVAILABLE	The coffee beans hopper is empty.	Carry out the supply (see section 7).
/	NOT AVAILABLE	A Type of product not available.	
/	NO CHANGE AVAILABLE	The level of coin stacking tubes is below the preset limit.	Add coins into the change-giving coiner.
/	NO LINK	No dialogue with the selected payment system is detected by the VM.	Check for dialogue with the payment system.

11.2 Error messages

During operation the vending machine is able to detect a series of faults that may lead to a full or partial blockage of its functions. In case of total blockage, the first line on the display will show the out-of-service message, while the second line will display the fault code; an example is given:

CALL FOR ASSISTANCE
OUT OF SERVICE 25

FAILURE CODE

In this case the vending machine is out of service. To bring it back into working order again, it is necessary to remove the cause of the fault and possibly carry out the error reset procedure described at 8.3.3.

Cause	Code	Message	Registered in ERROR LOG as error or warning	Effect	Error resettable by means of "Automatic Reset" procedure	Automatic reset at restarting	Error resettable from 5-key keypad
water level low in air break	1	" NO WATER 01"	W/E	blocked	YES*	YES	YES
no coffee dosing unit level detected (coffee not available?)	2	"COFFEE NOT AVAILABLE"	E	coffee blocked	YES	NO	YES
no movement of group gearmotor detected	3	"BREWING UNIT BLOCK03"	E	coffee blocked	YES*	YES	YES
no movement of group gearmotor detected	4	"BREWING UNIT BLOCK04"	E	coffee blocked	YES*	YES	YES
no flowmeter pulses detected	5	" NO FLOWMETER 05"	E	blocked	NO	NO	YES
no movement of dispensing arm detected	6	" ARM DISP. BLOCKED06"	E	blocked	NO	YES	YES
no movement of dispensing arm detected	7	" ARM DISP. BLOCKED07"	E	blocked	NO	NO	YES
no cups detected	8	" NO CUPS 08"	E	blocked	—	YES	YES
drip tank full	9	"DRIP TANK FULL 09"	E	blocked	YES*	YES	YES
no movement of cup release detected	10	" CUP DISP. BLOCKED10"	E	blocked	YES*	YES	YES
no movement of stirrer ejector detected	11	"SPOON DISP. BLOCKED "	E	blocked	NO	NO	YES
no movement of stirrer ejector detected	12	"SPOON DISP. BLOCKED "	E	blocked	NO	NO	YES
reading of temperature sensor out of range	13	"TEMP. SENSOR ERROR13"	E	blocked	NO	YES	YES
reading of coffee temperature sensor out of range	14	"TEMP. SENSOR ERROR14"	E	blocked	NO	YES	YES
e2prom corrupted	16	" E2CHECK ERROR 16"	E	blocked	NO	YES	YES
no movement of cup holder detected	17	"BASKET CUP BLOCKED17"	E	blocked	NO	NO	YES
no brew group detected	20	" BREWING UNIT N/A 20"	E	coffee blocked	YES*	YES	YES
no dreg drawer detected	21	—	E	—	—	YES	YES
abnormal flow detected in coffee brewing	22	" ABNORMAL FLOW 22"	W/E	coffee blocked	YES	NO	YES
pump timeout	23	" PUMP TIMEOUT 23"	W	message only	—	—	YES
no instant product boiler level detected	24	"BOILER FILLING ERR24"	E	blocked	—	—	YES
Saeco card without timekeeper detected	25	" TIMEKEEPER REQUIRED"	E	blocked	NO	YES	YES
setting of decimal point position detected not consistent with payment system	31	"DECIMAL POINT ERROR "	E	blocked	NO	YES	YES
credit management restarting message	32	—	E	message only	—	—	YES
pressing of CPU P3 key for 15 seconds detected	33	" OUT OF SERVICE 33"	E	blocked	NO	NO	YES
Normal operation restored message after abnormal flow	34	—	W	message only	—	—	YES
MDB slave error detected	35	—	W	message only	—	—	YES
coffee boiler heating slow	36	" BOILER1 ERROR 36"	E	blocked	NO	YES	YES
instant product boiler heating slow	37	" BOILER2 ERROR 37"	E	blocked	NO	YES	YES
CRC flash error	38	" CRC ERROR 38"	E	blocked	NO	NO	NO
BDV message	41	—	E	message only	—	—	—
watchdog intervention	72	—	YES	message only	—	—	—
change-giving coin error message	80	—	YES	message only	—	—	—
GSM modem error message	81	—	YES	message only	—	—	—
boiler triac overtemperature detected	82	—	YES	message only	—	—	—

12 STORAGE - DISPOSAL

12.1 Change of location



Should the vending machine be positioned in another site it is necessary to carry out the following operations:

- unplug the vending machine;
- empty the instant product, coffee bean and sugar containers;
- empty the AIR BREAK device. Remove the pipe cap (Fig. 94) and channel the water into a container. After draining the pipe completely, fit the cap back into its original position;

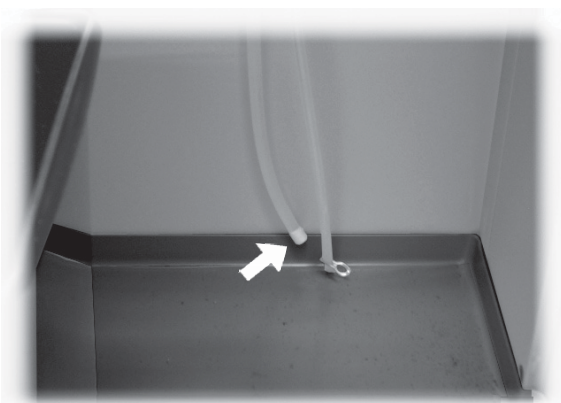

Fig. 94

- carry out the boiler draining cycle (maintenance menu);
- drain the water pipe. Remove the spring from the pipe (Fig. 95) and channel the water into a container. After draining the pipe completely, fit the spring back into its original position;

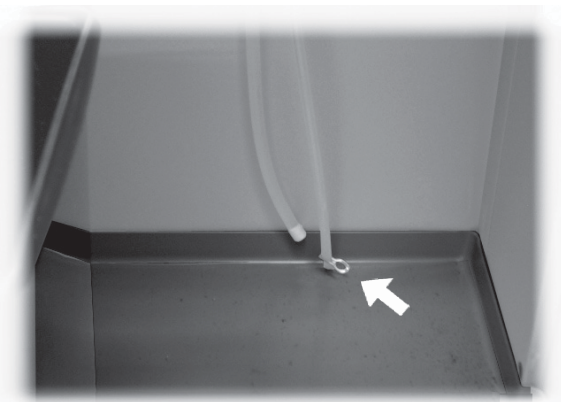

Fig. 95

- empty the coffee grounds bag (see 10.2.3);
- empty the fluid discharge tank and wash it (see 10.2.4);
- clean the vending machine as indicated in section 10;
- put the components back in place and close the doors;
- lift and position the vending machine in the site chosen as indicated at 5.2.

12.2 Inactivity and storage periods

If the vending machine needs to be stored or remains inactive for a long period, it is necessary to carry out the same operations as described at 12.1:

- wrap the vending machine in a tarpaulin to protect it from dust and damp;
- check that the vending machine is in a suitable place (the temperature should not be less than 1°C) taking care not to place any boxes or appliances over it.

13 INSTRUCTIONS FOR END-OF-LIFE DISPOSAL TREATMENT

This product complies with EU Directive 2002/96/EC.



The symbol  on the product or on its packaging indicates that this product may not be treated as household waste. Instead it shall be handed over to the applicable collection point for the recycling of electrical and electronic equipment.

By ensuring this product is disposed of correctly, you will help prevent potential negative consequences for the environment and human health, which could otherwise be caused by inappropriate waste handling of this product. For more detailed information about recycling of this product, please contact your local city office, your household waste disposal service or the shop where you purchased the product.



Warning

The disposal of the vending machine or of a part of it must be carried out with full respect of the environment and according to local laws in force.